

H-Spring Hydraulic Actuator

HDA-L (Linear) & HDA-R (Rotary)

Applications

The H-Spring actuator is a modular, high-pressure, hydraulic actuator designed for high-force linear or rotary valve control applications requiring failsafe functionality. Optionally, the actuator can be configured for either modulating or on/off services. Both custom and standard configurations are available to match the required application. H-Spring actuators are designed for use in the following types of applications:

- Utility steam turbine control valve
- Utility steam turbine stop valve
- Gas turbine – steam admission valves
- Gas turbine – bypass air valve
- General process applications

Woodward can supply the H-Spring as part of a complete actuator-valve assembly, or as a stand-alone actuator. Woodward can also provide valve automation or integration assistance.

The modularity of the H-Spring actuator allows it to be easily configured to match the required force output with the appropriate failsafe spring requirements to yield an actuator that is as compact as possible without compromising safety margin.

The actuator's integrated failsafe feature makes it ideal for critical valve applications, where failsafe protection is a system or plant requirement. This actuator's integrated failsafe design allows users to benefit from the removal of expensive and bulky external return springs and accumulators. Optionally this actuator can be configured to fail extend or fail retract.

Description

The H-Spring actuator is a double-acting hydraulic actuator that uses a failsafe design to enable it to provide fast and accurate valve control as well as force the valve to a safe position upon a system failure.

The H-Spring design provides the failsafe reliability of a single-acting actuator with the precise control and high power density of a double-acting actuator. The benefit to the user is an extremely compact and reliable package for a large, failsafe actuator. The unique design is enabled by the Hydraulic Spring (H-Spring) accumulators that provide the failsafe capability. These accumulators utilize extremely high reliability coil springs and hydraulic fluid to store the energy until action is required. They are much more reliable than traditional gas accumulators due to the gas accumulator tendency to leak over time.

This actuator series is packaged with integrated hydraulic filters, NEMA 4X electrical junction box, triple redundant servo coils, triple redundant feedback sensors (LVDTs), and redundant internal accumulators, to provide the most reliable actuator on the market in a simple and compact package.

This high-pressure 100–140 bar actuator family can be provided with a linear or rotary output shaft. The “linear” HDA-L series actuator can be configured to supply thrusts of 42–210 kN (9400–47 000 lbf) with stroke lengths ranging between 76–205 mm (3–8”) of travel.

The “rotary” HDA-R series actuator supplies torques between 4972 and 35 595 N·m (3667 and 26 250 lb-ft), depending upon actuator configuration. Available shaft output rotation ranges between 10 and 90 degrees. This actuator's integrated failsafe function incorporate a reliable piston-and-spring accumulator design to provide the motive force for failsafe operation. This design provides for failsafe operation in a compact package without compromising safety or reliability.

The H-Spring is an integrating actuator that accepts a +8 mA current signal from an external servo controller (not included) to control the unit's internal pilot valve. An electronic valve position controller like Woodward's SPC must be used in conjunction with the H-Spring to control its position. Integrated LVDTs are used to provide actuator/valve position feedback.



- Custom configurations available
- Integrated design
- Servo valves
- LVDTs
- Accumulators
- Field-reversible failure mode
- Redundant servo coils
- Redundant LVDTs
- Large force outputs
- Extremely fast acting
- Reliable operation
- Compact design
- Valve automation/integration available
- Steam and gas turbine valve applications
- Process valve applications
- NEMA 4X junction box

Outline Drawing of HDA-L (sample drawing only)

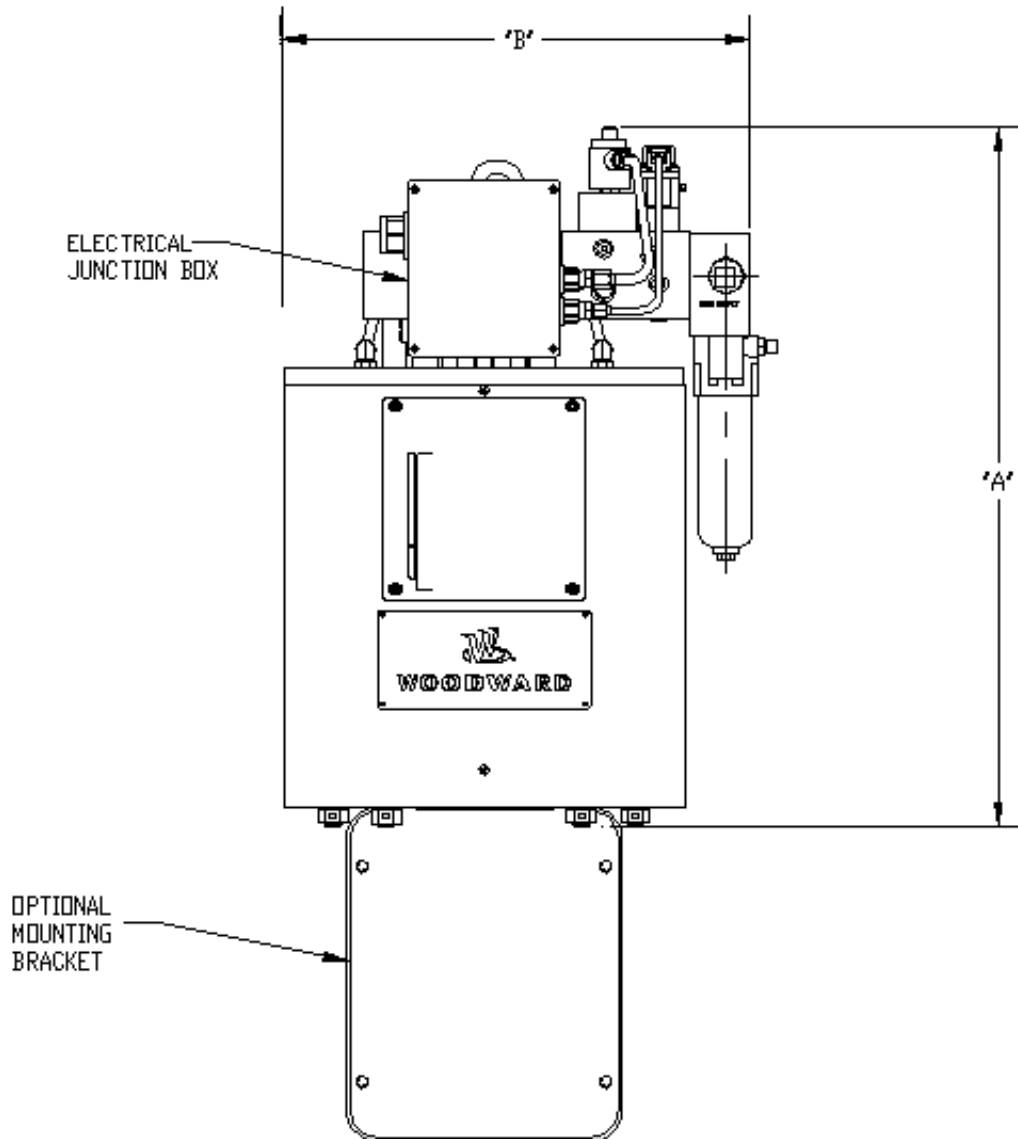

Common Estimated Weights and Dimensions—Consult Factory for Specific Data

PISTON SIZE (in / mm)	STROKE LENGTH (in / mm)	ESTIMATED WEIGHT (lb / kg)	A DIMENSION (in / cm)	B DIMENSION (in / cm)
3.0 / 76	3.0 / 76	725 / 329	35.8 / 91	25.3 / 64
3.0 / 76	3.0 / 76	725 / 329	35.8 / 91	25.3 / 64
3.0 / 76	4.0 / 102	1600 / 726	51.2 / 130	37.3 / 95
3.0 / 76	4.0 / 102	1600 / 726	51.2 / 130	37.3 / 95
3.0 / 76	5.0 / 127	1600 / 726	51.2 / 130	37.3 / 95
4.61 / 117.1	8.0 / 203	4800 / 2177	54.73 / 139.0	71.0 / 180
4.61 / 117.1	8.0 / 203	4800 / 2177	54.73 / 139.0	71.0 / 180
5.48 / 139.2	8.0 / 203	4800 / 2177	53.23 / 135.2	46.4 / 118
5.48 / 139.2	8.0 / 203	4800 / 2177	53.23 / 135.2	46.4 / 118

Outline Drawing of HDA-R (sample drawing only)

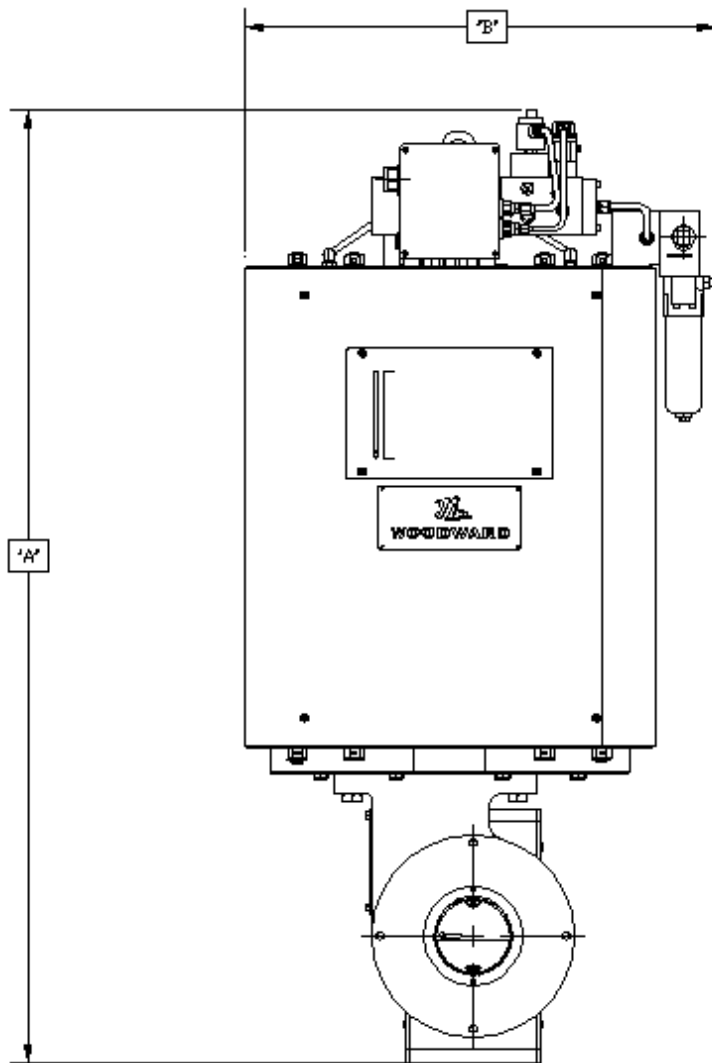

Common Estimated Weights and Dimensions—Consult Factory for Specific Data

PISTON SIZE (in / mm)	STROKE LENGTH (in / mm)	ESTIMATED WEIGHT (lbs / kg)	A DIMENSION (in / cm)	B DIMENSION (in / cm)
3.0 / 76	3.8 / 97	1600 / 726	77.9 / 198	39.4 / 100
3.0 / 76	6.0 / 152	2000 / 907	75.3 / 191	42.1 / 107
4.0 / 102	6.0 / 152	2000 / 907	76.7 / 195	42.1 / 107
4.61 / 117.1	8.0 / 203	4800 / 2177	89.2 / 227	56.1 / 142
5.48 / 139.2	8.0 / 203	4800 / 2177	83.5 / 212	56.1 / 142

Specifications

Output Shaft Diameter	25 mm (1"), 38 mm (1.5"), 51 mm (2")
Piston Diameter	Available in 76 mm (3"), 98.42 mm (3.875"), 117 mm (4.61 in), 139.2 mm (5.48")
Stroke Lengths	Up to 203 mm (8") of travel (depending on piston diameter)
Hydraulic Requirement	Materials: petroleum based and phosphate esters
Filtration Requirements	10 μ m absolute
Nominal Pressure	103–138 bar (1500–2000 psig)
Proof Pressure Level	207 bar (3000 psig)
Weight	329–2177 kg (725–4800 lb)

Electrical Specifications

Trip Contact Input Ratings	Trip contact: 125 Vdc or 24 Vdc
Input Demand Signal	Servo valve: ± 8 mA STD (impedance: 1000 Ω)
Position Feedback Signal	LVDT: 0.7–3.0 Vrms feedback (excitation signal: 7.0 Vrms at 3 kHz)

Environmental Specifications

Ambient Temperature Range	–29 to +66 °C (–20 to +150 °F)
---------------------------	--------------------------------

Regulatory Compliance

Product may be configured to be used in North American and European hazardous locations. Contact your local Woodward representative to discuss these applications.



PO Box 1519, Fort Collins CO, USA 80522-1519
 1000 East Drake Road, Fort Collins CO 80525
 Tel.: +1 (970) 482-5811 • Fax: +1 (970) 498-3058
www.woodward.com

Distributors & Service

Woodward has an international network of distributors and service facilities. For your nearest representative, call the Fort Collins plant or see the Worldwide Directory on our website.

This document is distributed for informational purposes only. It is not to be construed as creating or becoming part of any Woodward contractual or warranty obligation unless expressly stated in a written sales contract.

© Woodward 2006, All Rights Reserved

For more information contact:

2011/4/Colorado