



Installation and Operation Manual



3161 Governor

Manual 03101 (Revision C)

IMPORTANT



This is the safety alert symbol. It is used to alert you to potential personal injury hazards. Obey all safety messages that follow this symbol to avoid possible injury or death.

DEFINITIONS

- **DANGER**—Indicates a hazardous situation which, if not avoided, will result in death or serious injury.
- **WARNING**—Indicates a hazardous situation which, if not avoided, could result in death or serious injury.
- **CAUTION**—Indicates a hazardous situation which, if not avoided, could result in minor or moderate injury.
- **NOTICE**—Indicates a hazard that could result in property damage only (including damage to the control).
- **IMPORTANT**—Designates an operating tip or maintenance suggestion.

WARNING

The engine, turbine, or other type of prime mover should be equipped with an overspeed shutdown device to protect against runaway or damage to the prime mover with possible personal injury, loss of life, or property damage.

The overspeed shutdown device must be totally independent of the prime mover control system. An overtemperature or overpressure shutdown device may also be needed for safety, as appropriate.



Read this entire manual and all other publications pertaining to the work to be performed before installing, operating, or servicing this equipment. Practice all plant and safety instructions and precautions. Failure to follow instructions can cause personal injury and/or property damage.



This publication may have been revised or updated since this copy was produced. To verify that you have the latest revision, be sure to check the Woodward website:

www.woodward.com/pubs/current.pdf

The revision level is shown at the bottom of the front cover after the publication number. The latest version of most publications is available at:

www.woodward.com/publications

If your publication is not there, please contact your customer service representative to get the latest copy.



Any unauthorized modifications to or use of this equipment outside its specified mechanical, electrical, or other operating limits may cause personal injury and/or property damage, including damage to the equipment. Any such unauthorized modifications: (i) constitute "misuse" and/or "negligence" within the meaning of the product warranty thereby excluding warranty coverage for any resulting damage, and (ii) invalidate product certifications or listings.

NOTICE

To prevent damage to a control system that uses an alternator or battery-charging device, make sure the charging device is turned off before disconnecting the battery from the system.

NOTICE

To prevent damage to electronic components caused by improper handling, read and observe the precautions in Woodward manual 82715, *Guide for Handling and Protection of Electronic Controls, Printed Circuit Boards, and Modules*.

Revisions—Text changes are indicated by a black line alongside the text.

Woodward Governor Company reserves the right to update any portion of this publication at any time. Information provided by Woodward Governor Company is believed to be correct and reliable. However, no responsibility is assumed by Woodward Governor Company unless otherwise expressly undertaken.

© Woodward 1982
All Rights Reserved

Contents

CHAPTER 1. GENERAL INFORMATION.....	1
Description.....	1
References	1
CHAPTER 2. INSTALLATION PROCEDURES.....	3
Introduction	3
Storage	3
Installation Requirements	3
CHAPTER 3. PRINCIPLES OF OPERATION	6
Component Description	6
Operation of the 3161 Governor.....	8
CHAPTER 4. TROUBLESHOOTING	11
CHAPTER 5. GOVERNOR REPAIR	13
Introduction	13
Parts Inspection and Replacement	20
Governor Assembly	22
CHAPTER 6. GOVERNOR CALIBRATION	27
Introduction	27
General	27
Calibration	27
CHAPTER 7. AUXILIARY DEVICES.....	29
Introduction	29
CHAPTER 8. REPLACEMENT PARTS	34
Parts Information	34
Parts List for Figure 8-1	34
Parts list for Figure 8-2	36
CHAPTER 9. SERVICE OPTIONS	38
Product Service Options.....	38
Woodward Factory Servicing Options	39
Returning Equipment for Repair	40
Replacement Parts	40
Engineering Services.....	41
How to Contact Woodward.....	41
Technical Assistance.....	42

Illustrations and Tables

Figure 1-1. 3161 Governor Outline Drawing	2
Figure 3-1. Schematic of the 3161 Governor	10
Figure 5-1. Common Tools Used on the 3161 Governor	14
Figure 5-2. Special Tools Used on the 3161 Governor	14
Figure 5-3. Speeder Plug Removal	16
Figure 5-4. Terminal Lever Removal	16
Figure 5-5. Ballhead	17
Figure 5-6. Removing Ballhead Cover	17
Figure 5-7. Ballhead Disassembly	18
Figure 5-8. Accumulator Removal	18
Figure 5-9. Accumulator Loading Tool	19
Figure 5-10. Servo and Link Disassembly	20
Figure 5-11. Limit Shutdown Assembly	23
Figure 5-12. Drive Shaft Seal Assembly	23
Figure 5-13. Drive Shaft Retaining Rings	24
Figure 5-14. Speeder Plug Bracket Assembly	26
Figure 7-1. Manual Shutdown	29
Figure 7-2. Pressure Shutdown	30
Figure 7-3. Electric Shutdown	31
Figure 7-4. Pneumatic Speed Setting	31
Figure 7-5. Speed Adjusting Motor and Manual Speed Adjustment	32
Figure 7-6. Air Pressure Fuel Limiter	33
Figure 8-1. Parts for 3161 Governor	35
Figure 8-2. Parts for 3161 Governor	37
Table 2-1. Oil Viscosity Chart	5
Table 5-1. Common Tools	15
Table 5-2. Special Tools	15

Chapter 1.

General Information

Description

The 3161 governor is a mechanical-hydraulic device that senses speed and is mechanically linked to and controls the energy source of dual fuel engines, diesel engines, or steam turbines.

The maximum work output is 6 ft-lb (8 J) over the full 42 degrees travel of its output (terminal) shaft. The recommended travel of the output shaft is 28 degrees between the no-load and full load positions. This provides a maximum useful work of 4 ft-lb (5 J) for the 28 degrees output shaft travel.

The governor will operate as an isochronous governor (constant speed), or as a droop governor. Principles of operation of the 3161 governor are described in Chapter 3.

Governor speed setting can be achieved by a speed setting lever, or by various remote operated devices. See Chapter 7, Auxiliary Devices.

References

03102	Product Specification, 3161 Governor
25071	Oils for Hydraulic Controls
25075	Storage of Mechanical-Hydraulic Controls

METRIC

mm = INCH		mm = INCH		mm = INCH	
6	.03	22.2	.87	76.8	3.14
1.5	.06	22.4	.88	76.9	3.11
2.5	.10	24.5	.97	80.6	3.17
4.4	.17	28.6	1.13	82.5	3.25
8.7	.34	30.1	1.19	86.9	3.50
9.1	.36	38.5	1.52	95.3	3.75
10.3	.40	43.7	1.72	106.0	4.25
10.4	.41	44.7	1.76	109.2	4.30
11.1	.44	56.4	2.22	124.3	4.89
15.2	.60	62.4	2.46	134.1	5.28
15.7	.61	62.7	2.47	240.0	9.45
16.8	.66	71.5	2.81	245.7	9.67
16.9	.66	71.5	2.81	364.1	14.33
17.0	.67	75.0	2.95		
21.5	.85	75.5	2.97		

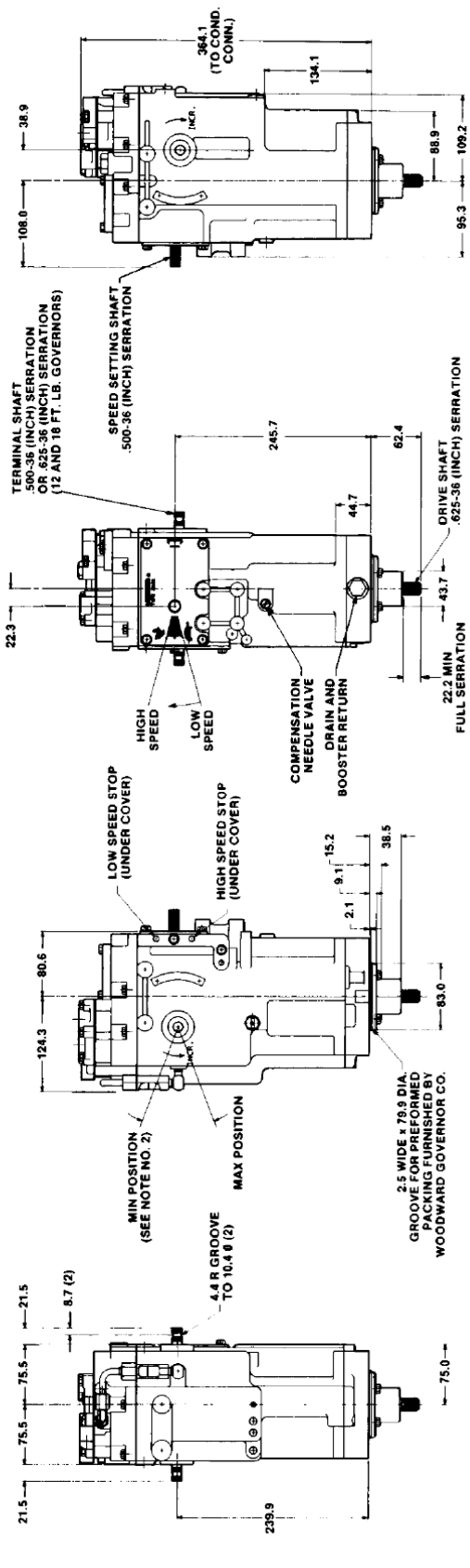
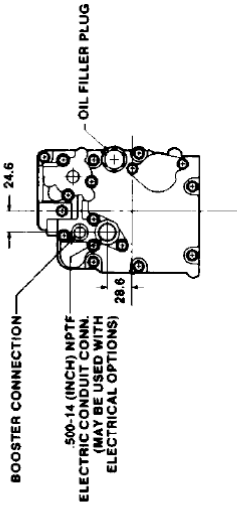

NOTE:

- DIRECTION OF PUMP ROTATION INDICATED BY ARROWS ON BASE AND PUMP HOUSING. ROTATE HOUSING 180° TO REVERSE DIRECTION OF ROTATION.
- 45° STROKE AVAILABLE. RECOMMENDED STROKE FOR NO LOAD TO FULL LOAD IS 28°.

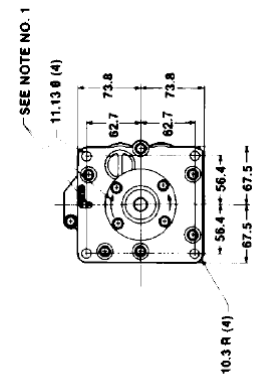

Figure 1-1. 3161 Governor Outline Drawing

03000-C-48

Chapter 2. Installation Procedures

Introduction

The 3161 governor is a precision instrument and should be handled as such. Damage can occur if the governor is dropped or set on the drive shaft, output shaft, or speed adjusting shaft.

Storage

The governor may be stored for a short period of time as received from the factory. Refer to manual 25075, *Commercial Preservation and Packaging for Storage of Mechanical-Hydraulic Controls*, if long term storage or storage in a hostile environment is necessary.

WARNING

The engine, turbine, or other type of prime mover should be equipped with an overspeed shutdown device to protect against runaway or damage to the prime mover with possible personal injury, loss of life, or property damage.

The overspeed shutdown device must be totally independent of the prime mover control system. An overtemperature or overpressure shutdown device may also be needed for safety, as appropriate.

Installation Requirements

Calibration fluid is drained from the governor before shipment from the factory, and additional cleaning or calibration is not required before installation on the prime mover.

Governor pump rotation is set at the factory. If a different rotation is required, refer to the Governor Assembly section of Chapter 5, for instructions to change the direction of governor pump rotation.

Be careful when setting the governor on the mounting pad. Use the correct drive coupling between the prime mover and governor. Be sure there is no binding, side loading of the drive shaft, or looseness in the drive coupling. The maximum run-out of drive shaft to mounting pad pilot should be less than 0.004 inch (0.10 mm). Careless alignment or improper mating of parts can result in premature wear or shaft seizure.

Output Shaft Linkage

Attach the prime mover linkage to the output shaft of the governor. The maximum work output of the 3161 governor is 6.0 ft-lb (8.1 J) over the full 42 degrees travel of its output shaft. The recommended travel of the output shaft is 28 degrees between the no load and full load positions. This provides a maximum useful work of 4.0 ft-lb (5.4 J) for the 28 degrees output shaft travel.

WARNING

With the output shaft of the governor rotated to the minimum position, the prime mover linkage must be adjusted to cause shutdown.

Speed Setting Shaft Linkage

Attach the speed setting linkage to the governor speed setting shaft. Typically, there will be a 50 rpm speed change for each degree of speed setting shaft rotation, however this may vary depending on the speed setting spring used in the governor. Maximum and minimum speed stops are adjusted during factory calibration of the unit.

Oil Supply

In general, the oil used in the prime mover will be satisfactory for use in the governor.

Fill the governor with clean, non-corrosive, oxidation and rust inhibiting oil that has minimum foaming or air retention qualities, and a viscosity of 100–300 SUS (Saybolt Universal Seconds) at operating temperature (typically 140–200 °F/ 60–93 °C). Fill to the line on the sight glass (approximately 2.3 US quart/2.2 L). After start-up, and when the oil is at operating temperature, again check the oil level and add more oil if necessary. Oil should be visible in the sight glass at all times.

Oil Viscosities

Table 2-1 shows the viscosity of oil at the different operating temperatures. The pour point (low temperature) is shown on the left and the temperature at which the performance of the oil begins to decrease is on the right side.

The governor will operate at temperatures near the pour point of the oil, but governor operation will be slow, and may be unstable. Do not operate the governor at a temperature less than the pour point of the oil.

Operating the governor at temperatures greater than the high limit (50 SUS), will decrease the stability of the governor, and may result in an inability to restart hot. Operating the governor at a temperature greater than the point at which the performance of the oil decreases can cause governor failure.

For specific oil recommendations, see manual 25071, *Oils for Hydraulic Controls*.

Start-up

Be sure all of the correct installation procedures have been followed. Start the engine according to the engine manufacturer instructions.



Be prepared to make an emergency shutdown when starting the engine, turbine, or other type of prime mover, to protect against runaway or overspeed with possible personal injury, loss of life, or property damage.

ANY OIL LISTED IS ONLY A SUGGESTION. USE THE OIL OF YOUR CHOICE WITH THE CORRECT VISCOSITY AS INDICATED IN THE CHART.

RECOMMENDED UPPER LIMIT OF PETROLEUM OIL IS 200°F
 RECOMMENDED UPPER LIMIT OF SYNTHETIC OIL IS 250°F

GOV OIL OPERATING TEMPERATURE	-40°F -40°C	0°F -18°C	40°F 4°C	80°F 27°C	120°F 49°C	160°F 71°C	200°F 93°F	240°F 118°C	
PETROLEUM OILS	POUR POINT		SAE 40			SAE 30			
	SAE 20			SAE 10			50 SUS LIMIT (7.5 CST)		
	SAE 10W30			SAE 10W40			SAE 20W40		
	SAE 15W40			TYPE A-F DEXRON II			ALL PROOF 10W50 (POLYESTER)		
	AMSOIL 10W40 (DIESTER)			DN 600 (HYDROCARBON)			MOBILE I (SYNTHESIZED HYDROCARBON)		
	DELVAC I (SYNTHESIZED HYDROCARBONS)								
	AUTO. TRANS. FLUID								

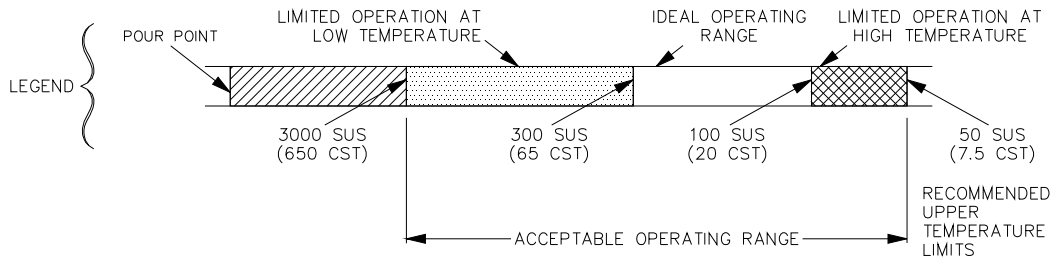

250-079

Table 2-1. Oil Viscosity Chart

Needle Valve Adjustment

After the prime mover has started and the governor is controlling, open the needle valve (turn it CCW) until governor operation just becomes unstable. Then slowly close the needle valve (turn it CW) until the governor just becomes stable. Allow the governor and prime mover to reach operating temperature. As the governor warms up, it may become unstable. If so, slowly close the needle valve until the governor just becomes stable. DO NOT fully close needle valve. This may cause excessive overspeed on start-up or load rejection.

Chapter 3.

Principles of Operation

Component Description

Gerotor Oil Pump—The gerotor oil pump is located in the base of the governor. The inner rotor of the pump is driven by a pin in the drive shaft, and carries the outer rotor around in mesh, pumping oil to the accumulator piston.

Accumulator—A single accumulator, consisting of a piston and spring, acts as a relief valve for the oil pump and provides a reservoir of high pressure oil for quick servo movement. Oil is pumped to the accumulator by the governor pump, with pressure increasing as the accumulator spring is compressed. When the pressure builds to the predetermined level, oil is released back to sump through relief ports in the piston wall.

Power Piston—The power piston is attached to the output shaft by a link and lever assembly. The power piston is designed with a large area on the bottom and a small area on top (differential piston). A small pressure increase on the large area of the piston will move the piston up, causing the output shaft to rotate in the “increase” direction. The piston can move down only when oil under the piston is released to sump. Oil to or from the bottom of the power piston is regulated by the ballhead pilot valve and ballhead pilot valve bushing.

Pilot Valve System

The pilot valve system consists of two components, the ballhead pilot valve (rotating) bushing, and the ballhead pilot valve plunger. The bushing is rotated relative to the pilot valve plunger to reduce friction between the two parts. The control land of the pilot valve plunger regulates the flow of control oil through the control ports of the ballhead bushing.

When the pilot valve plunger is lowered, high pressure oil moves through the control port of the bushing, to the bottom side of the power piston, and the piston moves up. When the pilot valve plunger is raised, the oil from the bottom of the power piston is released to sump, and the higher pressure on top of the piston moves the piston down. When the prime mover is running at steady state, the control land of the pilot valve plunger covers the porting in the ballhead bushing and the power piston does not move. The movement of the pilot valve plunger is controlled by the ballhead assembly.

Ballhead Assembly

The ballhead system consists of a ballhead, fly-weights, speeder spring, thrust bearing, and speeder plug. The ballhead, as part of the pilot valve bushing, is rotated by the drive coupling and drive shaft.

As the ballhead rotates, the centrifugal force causes the flyweights to pivot outward. At the same time, the speeder spring is forcing the thrust bearing down on the flyweight toes opposing the centrifugal force of the flyweights. Pushing down on the speeder plug increases the downward pressure on the speeder spring, and the governor speed setting is increased. The prime mover then runs at a higher speed to produce a higher centrifugal force on the flyweights to overcome the speeder spring force and rebalance the system.

Speeder spring force or speed setting is controlled through the speed adjusting shaft.

Compensation System

If the pilot valve plunger is lowered, pressure oil flows to the bottom of the power piston pushing it up, lifting the terminal lever, which in turn rotates the output shaft.

As the power piston moves up, the oil on top of the power piston is forced out into the passage leading to the upper side of the buffer piston, and to the lower side of the compensation land on the pilot valve. The buffer piston moves down, partially relieving the compression of the upper buffer spring and increasing the compression of the lower buffer spring. The force change of the buffer springs tends to resist this movement, resulting in a slightly higher oil pressure on the upper side of the buffer piston. This higher pressure is transmitted to the underside of the compensation land of the pilot valve plunger. The pressure on the lower side of the compensation land produces a force which acts to push the pilot valve plunger back to its centered position.

The force of the pressure differential on the compensation land moves the pilot valve towards its centered position. Due to the compensation forces, the pilot valve re-centers, although the engine speed is not back to normal. Leakage of oil through the needle valve orifice equalizes the pressures above and below the compensation land, and allows the engine speed to return to normal. As the pressures above and below the compensation land become equal, the buffer springs return the buffer piston to the centered position.

Speed Droop

The 3161 governor is an isochronous governor with the ability to operate in the droop mode by the adjustment of the internal droop pivot pin. The governor may be used in the droop mode to allow for load division between two or more prime movers connected to a single shaft or for operating in parallel.

The droop pivot pin is attached to the terminal lever located inside the governor. If droop has been set, the following occurs: As the output shaft of the governor rotates in the increase direction, the compression of the speeder spring is reduced, which in turn reduces the governor speed setting. The speed of the prime mover is reduced as load is applied. As the output shaft of the governor rotates in the decrease direction, the compression of the speeder spring is increased, which raises the speed setting of the governor as load is decreased.

Limit/Shutdown Pilot Valve

Shutdown of the prime mover is accomplished with the limit/shutdown pilot valve. With the prime mover running on speed, the ballhead pilot valve is in the centered position. When the limit/shutdown pilot valve is lowered, pressure oil above the control land of the ballhead pilot valve is drained back to the sump area. As prime mover speed begins to slow, ballhead flyweights move in, lowering the ballhead pilot valve plunger. Oil under the power piston is then drained to the sump area. As the power piston moves down, the output shaft is rotated in the decrease direction, and the prime mover is shut down.

Operation of the 3161 Governor

The schematic arrangement of the 3161 governor is shown in Figure 3-1, with the governor pilot valve calling for increased fuel. The 3161 governor has a self-contained oil supply (approximately 2.3 US qt/2.2 L). The oil passes from the suction side to the pressure side of the gerotor pump as the drive shaft is rotated by the prime mover. Pump pressure is regulated at approximately 100 psi (690 kPa) by the accumulator spring and piston. As the pressure increases, the accumulator piston moves up in the cylinder until 100 psi (690 kPa) is obtained. At this time, bleed ports in the piston are uncovered, and pump pressure is regulated.

The pressure generated by the accumulator, determines the work capabilities of the governor. Pump pressure is also used for the auxiliary devices installed on the cover.

Increase in Speed Setting

Rotating the speed setting shaft clockwise (CW) increases the speed setting of the governor. (The high speed stop screw limits the high speed setting of the governor.) As the speed setting shaft rotates, the speed setting lever pushes down on the floating lever which is attached to the speeder plug. The downward pressure on the speeder plug compresses the speeder spring and overcomes the centrifugal force of the ballhead flyweights to lower the ball-head pilot valve plunger (pvp), increasing speed setting of the governor.

When the pvp is lowered, pressure oil moves under the power piston causing it to move up, lifting the terminal lever and rotating the output shaft towards the increase direction. Even before the prime mover has reached the new set speed, the compensation system starts to re-center the pvp. As the power piston moves up, the oil on top of the power piston is forced out to the buffer piston and to the lower side of the compensation land on the pvp. The change in force on the two buffer springs tends to resist the movement of the buffer piston, causing a slightly higher oil pressure on the upper side of the buffer piston, with this pressure being transmitted to the bottom side of the pvp compensation land. The difference in pressures on the two sides of the compensation land produce a force which acts to push the pvp back to its centered position.

Leakage, of oil through the needle valve orifice equalizes the pressures above and below the compensation land, and allows the buffer piston to re-center during speed changes. As the pressures above and below the compensation land become equal, the buffer springs return the buffer piston to its centered position.

Decrease in Speed Setting

Rotating the speed setting shaft counterclockwise (CCW) decreases the speed setting of the governor (the low speed stop screw limits the low speed setting of the governor). As the speed setting shaft rotates CCW, the force of the speed setting lever on the floating lever is removed and the compression is reduced from the speeder spring. Centrifugal force from the flyweights raises the ballhead pilot valve plunger (pvp), uncovering the control port in the rotating bushing. Control oil under the power piston now drains to sump, allowing the power piston to move down. The output shaft rotates in the decrease direction, and the speed (rpm) of the prime mover is decreased. The compensation system then brings the governor under stable control.

Shutdown

The limit/shutdown pilot valve is located in the supply line to the ballhead pilot valve plunger. When shutdown is initiated, the shutdown strap pushes the limit/shutdown plunger below the supply passage and drains oil from the supply to the ballhead pilot valve plunger. Control oil from under the power piston drains past the control land of the pvp, lowering the power piston and rotating the output shaft in the decrease direction. As the rpm of the prime mover decreases, the ballhead flyweights move in, lowering the ballhead pilot valve, rapidly draining the oil from under the power piston. As the power piston moves down, the output shaft rotates to the shutdown position and the prime mover is shutdown.



With the output shaft of the governor rotated to the minimum position, the prime mover linkage must be adjusted to cause shutdown.



Be prepared to make an emergency shutdown when starting the engine, turbine, or other type of prime mover, to protect against runaway or overspeed with possible personal injury, loss of life, or property damage.

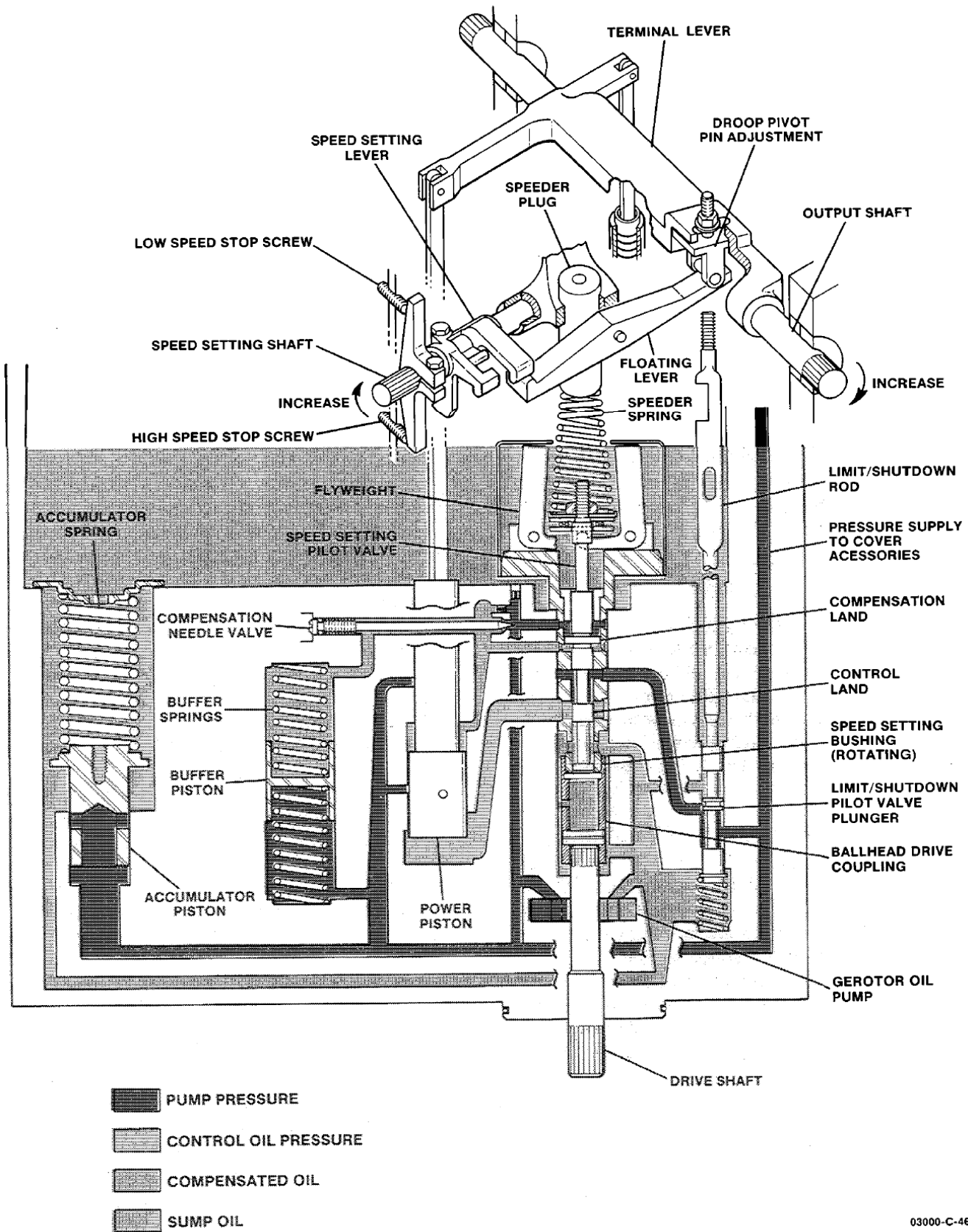

03000-C-46

Figure 3-1. Schematic of the 3161 Governor

Chapter 4. Troubleshooting

Governor faults are usually revealed as speed variations of the prime mover, however, it does not necessarily follow that all speed variations indicate governor faults. Troubleshoot the governor to localize a problem before attempting disassembly and repair.

Use the following Troubleshooting Diagram to troubleshoot your governor. See Chapter 6, Governor Calibration, or refer to the engine manufacturer's specifications for engine calibration.

 **WARNING** Be prepared to make an emergency shutdown when starting the engine, turbine, or other type of prime mover, to protect against runaway or overspeed with possible personal injury, loss of life, or property damage.

Problem	Question	Procedure
Engine cranks, but governor output shaft doesn't move from minimum position.	With manual assistance, can the governor output shaft be easily moved towards maximum while cranking?	YES— <ol style="list-style-type: none"> 1. Is governor filled with oil? 2. Is the rotation of the pump set correctly? 3. Have you cranked the engine for at least 10 seconds to allow the governor time to develop pressure? 4. Is the drive shaft connected? 5. Is the oil viscosity greater than 50 SUS? 6. Is the cranking speed too low? NO— <ol style="list-style-type: none"> 1. Are any shutdown devices activated or incorrectly adjusted? 2. Is speed setting above cranking speed? 3. Is linkage free from excessive friction? 4. Is load limit set at zero? 5. If fuel limiter is used, is it correctly adjusted?
Governor opens fuel, but is slow and sluggish.		<ol style="list-style-type: none"> 1. Are shutdowns properly adjusted? 2. Is the governor oil viscosity less than 50 SUS, or above 3000 SUS? 3. Is the need valve closed too far? 4. Is linkage to the engine free?
Governor opens fuel, but only part way.		<ol style="list-style-type: none"> 1. Is load limited adjusted properly, and set out of the way? 2. Is there adequate manifold pressure? [applies to fuel limit type governors] 3. Is fuel stop on engine adjusted properly? 4. Is fuel stop in governor set properly? 5. Is fuel linkage free?
Governor opens fuel and prime mover starts, but trips out on overspeed.		<ol style="list-style-type: none"> 1. Is the linkage sticky? 2. Is the linkage properly adjusted? 3. Is the overspeed trip set properly? 4. Is the needle valve closed too far? 5. Is the governor speed setting too high?
System oscillates and is unstable.		Check the following: <ol style="list-style-type: none"> 1. Is droop properly set? 2. Is the needle valve correctly adjusted? 3. Is linkage sticky or worn?

Problem	Question	Procedure	
Prime mover will not accept full load.	Is the governor at full fuel?	YES— 1. Is the linkage adjusted properly? 2. Is load excessive? 3. Is the voltage regulator (if used) set properly? 4. Is the fuel stop on the prime mover set correctly?	
		NO— 1. Is the load limit out of the way, and adjusted properly? 2. Is the fuel limited (if so equipped) set too low? 3. Is there adequate air pressure for the fuel limiter? 4. Is the linkage sticky or improperly adjusted? 5. If electric start fuel limiter—is there adequate voltage for the solenoid?	
Needle valve adjustment does not eliminate instability.	(1) Are the oscillations periodic and smooth (not intermittent)?	YES— Go to question (2). NO— Check the following: 1. Is the fuel source adequate and constant? 2. Is the speed setting reference steady? 3. Is the governor oil level low? 4. Is the load erratic? 5. Is the governor oil clean?	
	(2) Is the frequency of the oscillation above 5 Hz?	YES— Check the following: 1. Governor drive train. 2. Governor alignment. 3. Dirty spring-driven oil damped ballhead (if so equipped). 4. Bad injector or misfire? NO— Go to question (3).	
	(3) Are the oscillations related to speed setting variations?	YES— The cause of the speed setting variation must be found and corrected. NO— Go to question (4).	
	(4) Does the oscillation disappear when blocking governor output or operating hand throttle?	YES— 1. Is linkage loose or worn? 2. Is governor part number correct for this application? 3. Replace governor. NO— 1. Check for load fluctuations. 2. Check fuel supply. 3. Check for loose or sticky linkage.	
	 WARNING		When blocking governor output or operating the hand throttle, the system is not under governor control, and extreme caution must be taken to prevent overspeed. Do not attempt if overspeed speed device is not functioning.
	Governor will not shut prime mover down.	Is governor at minimum fuel position?	YES— Linkage is improperly set to allow shutdown.
			NO— 1. Is shutdown actuation signal available at the governor? 2. Are shutdowns properly adjusted? 3. Is shutdown strap in governor properly adjusted? 4. Close off fuel and replace governor.

Chapter 5. Governor Repair

Introduction

Chapter 5 provides instruction for the disassembly, inspection, cleaning and repair of the 3161 governor.

CAUTION

Wear approved eye protection during disassembly, cleaning, and assembly of parts, to prevent possible eye injury.

NOTICE

This governor is a precision device and should be treated as such. Set the governor upright on wooden blocks to protect the drive shaft. Do not drop or set the governor on the drive shaft as this may cause damage to the drive shaft, bearings, seals and other parts inside the governor.

Troubleshoot the governor before disassembly and repair. Do not disassemble any further than necessary to correct governor malfunction. All governor disassembly and repair should be done by personnel experienced in governor repair and calibration. In all governor repair work, it is essential that all tools, the work area and governor parts be kept clean.

Remove Governor from Mounting Pad

1. After the governor has been removed from the engine, remove drain plug (93) and drain as much oil as possible from the case.
2. Clean exterior surface of the governor with a cloth and solvent.

General Disassembly

1. Do not remove or disturb the position of screws or levers which function as adjustments. Do not disassemble linkages further than required to effect removal, unless replacement is necessary.

NOTICE

Handle critical parts with care. Keep them separated so mating surfaces are not damaged. Sharp corners of plunger lands, piston grooves, metering ports, etc., must be maintained. Rounded corners, nicks or other damage to such areas will result in excessive internal leakage and decreased control sensitivity.

2. Discard gaskets, O-rings, oil seals, retaining rings, cotter pins, and roll pins removed during disassembly.

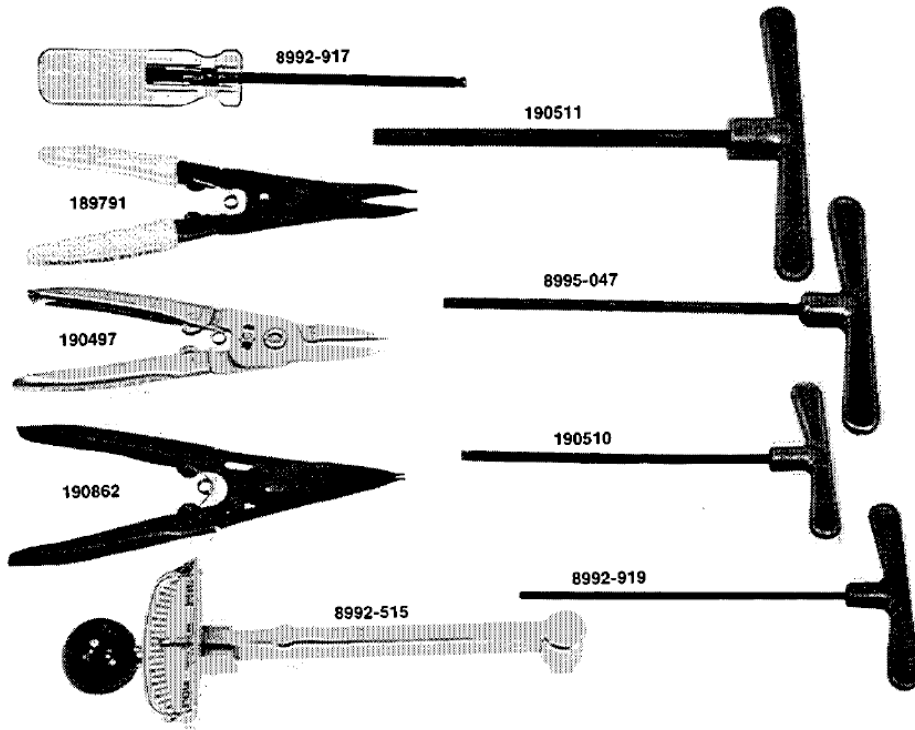

Figure 5-1. Common Tools Used on the 3161 Governor

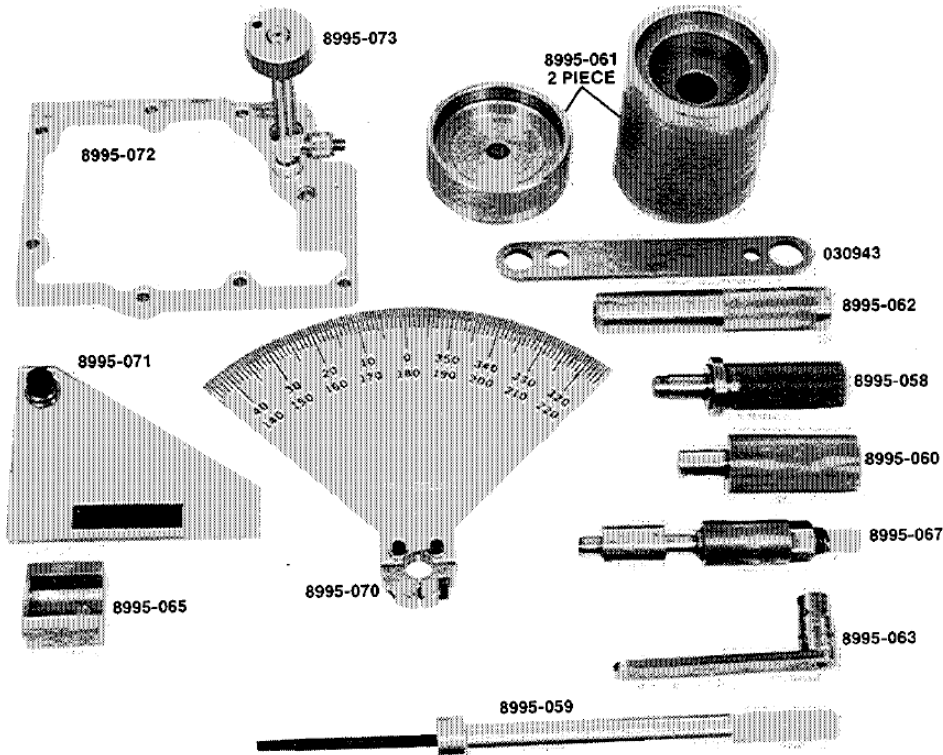

Figure 5-2. Special Tools Used on the 3161 Governor

Tools

See Figures 5-1 and 5-2 for tools to facilitate the disassembly and assembly of the governor. Not all of these tools may be needed, depending on the degree of disassembly.

Tools can be ordered from Woodward (Fort Collins, Colorado, USA). Include in the order:

- Description of the tool
- Part number of the tool requested
- Manual Number 03101

Table 5-1. Common Tools

Part Number	Part Name
8992-919	1/8 inch T-handle Allen wrench
190510	5/32 inch T-handle Allen wrench
8995-047	3/16 inch T-handle Allen wrench
190511	5/16 inch T-handle Allen wrench
8992-917	3/16 inch ball end Allen wrench
8992-515	3/8 inch drive torque wrench (0–100 lb-in)
190497	Pliers—ID snap ring
189791	Pliers—ID snap ring
190862	Pliers—OD snap ring

Table 5-2. Special Tools

Part Number	Part Name
8995-057	Torque wrench with clutch adapter
8995-058	Installation tool—pump seal and base bearing
8995-059	Loader—accumulator spring
8995-060	Insert tool—output shaft oilite bushings
8995-061	Two piece ballhead cover tool
8995-062	Adjuster—oilite bushing
8995-063	Wrench—fuel limit nut
8995-065	Press fixture—speeder plug
8995-067	Insert tool—speed setting shaft bearing
8995-068	Serrated Torque adapter—5/8-36 (not shown)
8995-069	Serrated Torque adapter—1/2-36 (not shown)
8995-070	Protractor
8995-071	Pointer
8995-072	Test cover
8995-073	Positioning tool—terminal lever
030943	Serration wrench—output shaft

Governor Disassembly

Disassemble the governor according to the following instructions. Reference numbers in parentheses are assigned to each part in the exploded views, Figures 8-1 and 8-2.

1. Remove eight 3/8 inch hex head cover screws (1), and cover (10). Turn the governor upside down and drain the remaining oil from the case.
2. Remove nameplate (30). Loosen clamp screw (1) in speed setting lever (36). Remove speed setting shaft (28)

3. Remove three screws (1) and lift out speeder plug bracket (37), shutdown/limit rod (40), limit floating lever (41), and limit rod (42).
4. Carefully push down on speeder plug (123) and turn it until the floating lever (125) is clear of the terminal lever. Lift speeder plug (123) and speeder spring (122) out of the ballhead (Figure 5-3).

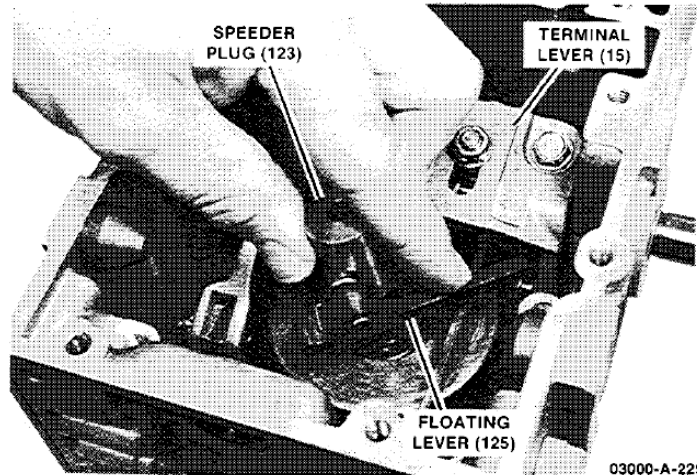

Figure 5-3. Speeder Plug Removal

IMPORTANT

Do not disassemble the speeder plug assembly unless part replacement is necessary. To remove pin (126), place the assembly on press fixture 8995-065. Use 1/8 inch pin punch and an arbor press to press the pin from plug (123).

5. Remove two screws (1) from the terminal lever (15). Pull output shafts (25) from the terminal lever (15) and case (26).
6. Lift terminal lever (15) up and rotate it to rest on the governor case. Remove cotter pin (14) and headed pin (22) to separate the terminal lever from servo connecting link (102). Remove seat (18) and spring (19) (Figure 5-4).

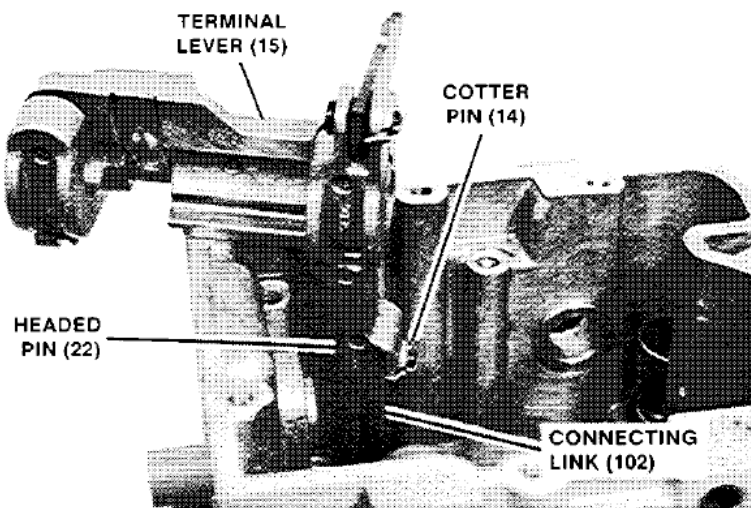

Figure 5-4. Terminal Lever Removal

7. Remove the ballhead assembly from the governor. Drive coupling (108) may come out with the ballhead assembly. If not, it will drop out when the governor is turned over (Figure 5-5).

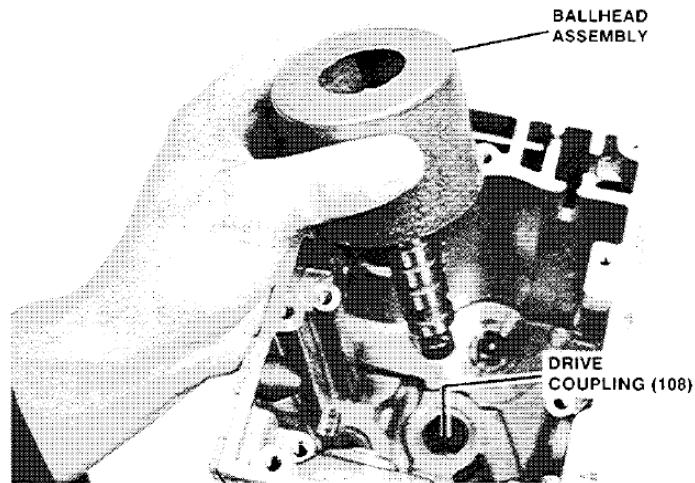

Figure 5-5. Ballhead

8. Use an 1/8 inch Allen wrench to hold the pilot valve plunger while removing nut (119). Remove race (118), bearing (117), race (116).
9. Use ballhead cover tool 8995-061, an arbor press, and a brass drift to press the ballhead from the ballhead cover (120) (Figure 5-6).

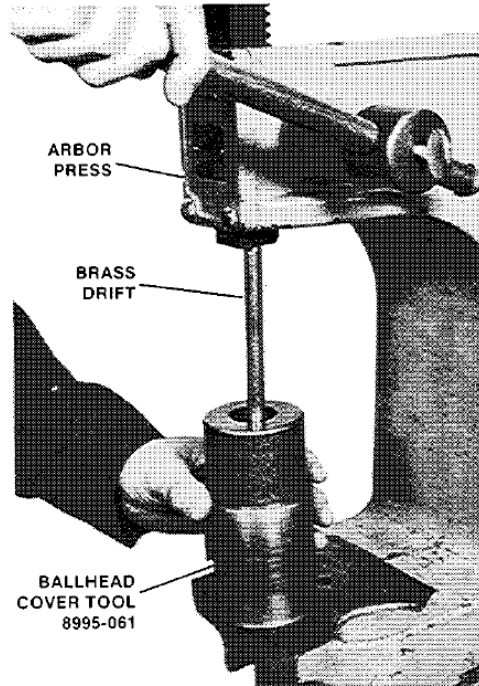

Figure 5-6. Removing Ballhead Cover

NOTICE

Press on the ballhead as close to the center as possible. Do not press on pilot valve plunger (112), compensation bushing (113), or flyweights (110).

10. Gently tap on the end of flyweight pins (106) to remove from ballhead (109). Use ID snap ring pliers 189791 to remove snap ring (114). Carefully remove pilot valve plunger (112), and compensation bushing (113) from ballhead (109) (Figure 5-7).
11. Screw spring loader 8995-059 into accumulator piston (78) to compress accumulator spring (77). Remove two screws (75) from spring seat (76). Remove the accumulator assembly (Figure 5-8).

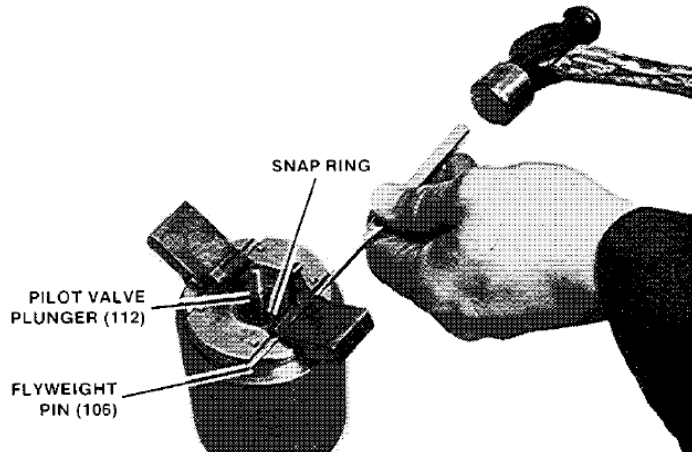

Figure 5-7. Ballhead Disassembly

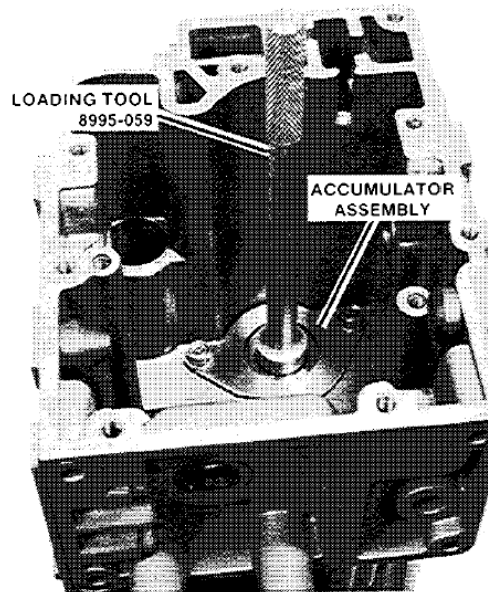

Figure 5-8. Accumulator Removal

CAUTION

To prevent physical injury or damage to the piston, be careful when removing spring loader 8995-059 from the accumulator piston. The accumulator spring is compressed between the spring seat (76) and accumulator piston (78). Take proper precautions while removing the tool. Use an arbor press as shown in Figure 5-9, to relieve compression of the accumulator spring.

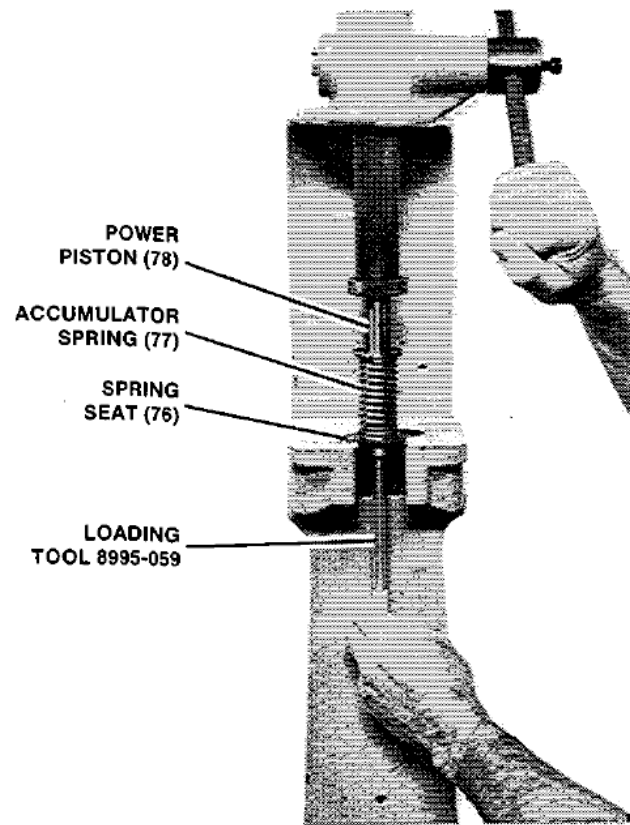

Figure 5-9. Accumulator Loading Tool

12. Turn the governor upside down. Remove four screws (75) from pump housing (82).
13. Remove pump housing (82) from base (95). Use two screwdrivers to gently lift the pump housing until it is free from the base.
14. Disassemble the pump assembly. Remove pump gears (79) from drive shaft (86). Remove retaining ring (90) from pump housing. Remove drive shaft (86) and bearing (88). Remove retaining rings (87 and 89) from the drive shaft.
15. Remove seven base screws (75), base (95) and base to case gasket (96).
16. Remove buffer springs (97) and buffer piston (101).
17. Remove spring (98) and limit/shutdown pilot valve (100).
18. Remove servo piston (103) and link (102). To remove the link from the servo piston, press double diameter pin (104) from opposite side of the chamfered hole (Figure 5-10).

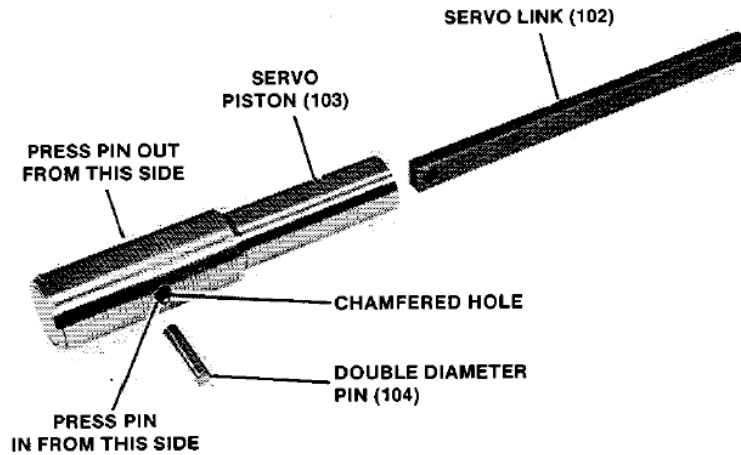

Figure 5-10. Servo and Link Disassembly

19. Remove two screws (1), cover plate (35) and stop screws (34).
20. Remove needle valve (127) and air bleed plug (129).

IMPORTANT

Do not remove oilite bearings unless replacement is necessary.

Cleaning**CAUTION**

Wear approved eye protection during disassembly, cleaning, and assembly of parts to prevent possible eye injury.

Parts with sharp corners and smooth finishes must be cleaned separately with solvent and a brush to avoid nicks and scratches. Other parts may be cleaned by agitation or in an ultrasonic cleaner.

Parts may be dried with clean, lint free wipes, or blown dry with clean dry air.

Parts that have sharp corners and have been machined to a close tolerance, must be handled carefully to prevent damage caused by contact with other parts or objects.

Parts Inspection and Replacement**General**

1. Inspect all moving parts for wear, corrosion, nicks, cracks, or other damage. Mating or rubbing surfaces must be examined closely for wear and scored surfaces.
2. Needle bearings, ball bearings and oilite bearings must not be degreased. Replace drive shaft bearing after 20,000 hours of operation.

3. Pistons, output shafts, speed setting shaft and the drive shaft may be lightly polished with a fine grit cloth or paper to restore a smooth finish to the bearing surface.
4. Inspect all springs for rust and corrosion.

Inspection Procedure

The following instructions are for parts that are considered to be the most vulnerable to wear, but all parts should be visually inspected.

Droop Pin (20)

Inspect the droop pin for wear in the area of contact with floating lever (125). A flat spot worn on this pin can cause a change in the droop setting.

Connecting Pin (22)

Check the pin for wear caused by up and down motion of the servo connecting link (102).

Output Shafts (25)

Inspect the bearing and seal area of the shafts for wear. Polish slight seal marks with fine grit paper.

Speed Setting shaft (28)

Inspect the bearing and seal area of the shaft for wear. Polish slight seal marks with fine grit paper, or relocate the seal slightly to ensure against leakage.

Pump Element (79)

Inspect the pump element for wear.

Pump Housing (82)

Inspect the housing for wear and damage. Be sure there is no evidence of galling on the wall next to the outer pump gear.

Drive Shaft (86)

Inspect the shaft for damage to the serrations, and for oil seal wear. The drive shaft must slip freely into the engine drive coupling. Polish light seal wear with fine grit paper.

Limit/Shutdown Pilot Valve (100)

The control land must have sharp corners and be void of nicks and scratches.

Servo Connecting Link (102)

Check the .251 diameter hole for elongation.

Ballarm Pin (106)

Inspect the pins for brinelling on the bearing area. Replace pins if there is any measurable wear.

Ballhead (109)

Serrations on the ballhead bushing must slip freely into drive coupling (108). Nicks and burrs on the ballhead will cause problems when installing the ballhead cover.

Ballarms (110)

Replace the ballarms if the toes have a worn flat that exceeds .030 inch in width.

Ballarm Bearings (111)

Replace rough or seized bearings. Replace bearing if measurable wear marks were found on pins (106).

Pilot Valve Plunger (112)

The control and compensation land must not have nicks or scratches, and sharp corners must be retained.

Thrust bearing (117)

Top and bottom races (116-118). Bearing race (116) must not be worn from ballarm toes. The rollers in bearing (117) must be clean and roll freely.

Floating Lever (125)

Inspect for wear where droop pin contacts the lever. Inspect for wear in area of contact with the speed setting lever.

Governor Assembly

To prepare to assemble the governor, lay the parts in an orderly fashion on a clean dry work surface. Lubricate all O-rings with white petroleum jelly to facilitate assembly.

Use only new O-rings, seals, gaskets and cotter pins. Careful, precise assembly methods will save time and help to ensure correct calibration of the governor.

Torque all 1/4 - 20 screws to 90 lb-in (10 N·m).

Assembly Procedures

1. Install O-ring (128) on needle valve (127) and install it in case (26).
2. Install O-ring (130) on air bleed plug (129) and install it in case (26).
3. Install stop screws (34). Leave screws (1) on cover plate (35) loose until after the governor is calibrated.
4. Assemble servo piston (103) and link (102). Start double diameter pin (104) into the chamfered hole in servo piston (103). Align hole in link (102) with pin, and press the pin in. Be sure the pin does not protrude from either side of the piston. Install the piston assembly in the case.
5. Turn case (26) bottom side up. Install retaining ring (99) on limit/shutdown pilot valve (100). Install spring (98) on the spring seat of plunger (100) and install this assembly in the case (Figure 5-11).
6. Install one buffer spring (97), buffer piston (101), and second buffer spring (97) in the buffer bore of case (26).
7. Place base gasket (96) on case (26). Install and secure base (95) with seven screws (75).

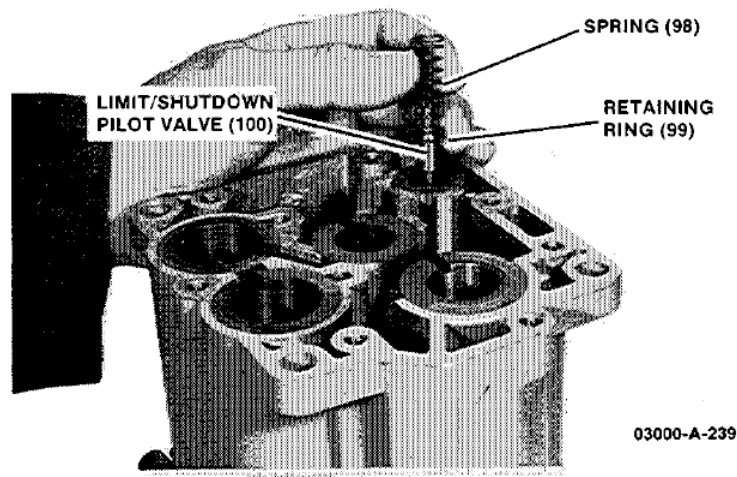

Figure 5-11. Limit Shutdown Assembly

8. Press drive shaft seal (84) to bottom of pump housing (82) (Figure 5-12).

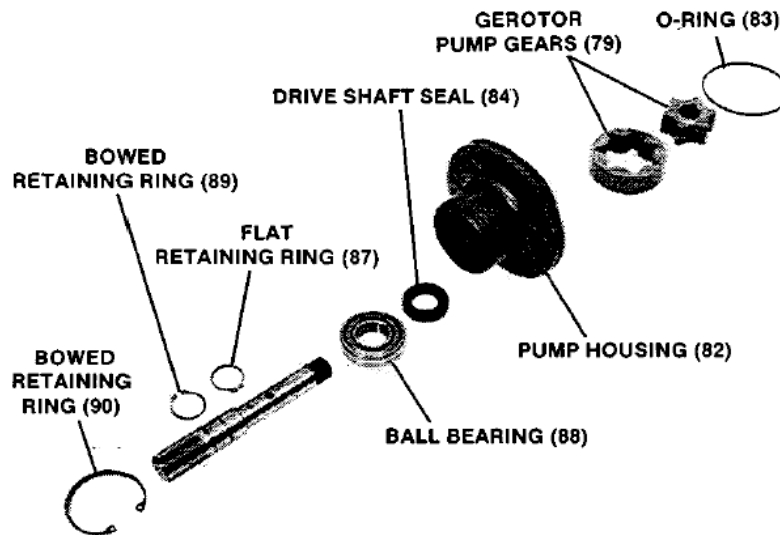

Figure 5-12. Drive Shaft Seal Assembly

9. Install bowed retaining ring (89) on drive shaft (86). Press bearing (88) on the shaft. Install flat retaining ring (87) (Figure 5-13).
10. Insert drive shaft (86) through seal (84) until the bearing is seated in pump housing (82). Secure the drive shaft assembly in the pump housing with bowed retaining ring (90).
11. Place gerotor pump gears (79) in pump housing (82), and O-ring (83) in the O-ring groove.

IMPORTANT

See engine or governor test specifications for correct governor pump rotation. Clockwise or counterclockwise rotation is as it is viewed from the top of the governor.

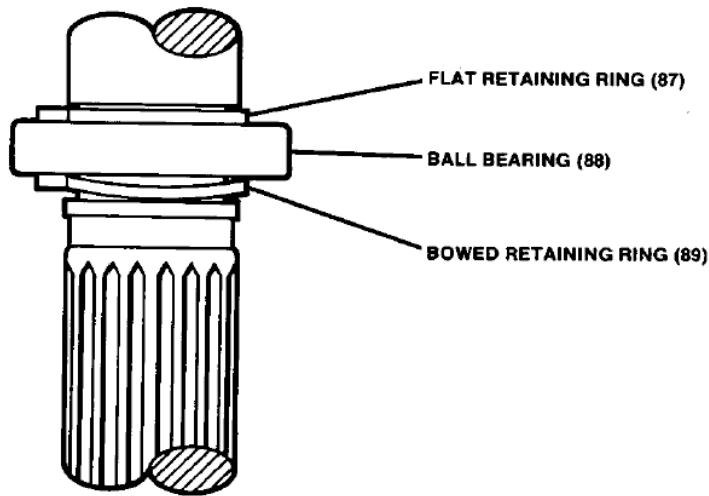

Figure 5-13. Drive Shaft Retaining Rings

12. Install the drive shaft and pump assembly in base (95). Match the arrow on pump housing (82) with the arrow on base (95) for the correct drive rotation for your governor.
13. Secure the pump housing with four screws (75).
14. Turn the governor over with the base supported by wooden blocks to protect the drive shaft.
15. Refer to Figure 5-9 to assemble the accumulator assembly. Place spring seat (76) bottom side up on the arbor press. Place spring (77) on the spring seat, and place accumulator piston (78) on the spring. Carefully compress the spring, and screw spring loader 8995-059 into the accumulator piston. Place this assembly in the case and secure with two screws (75).

Ballhead Assembly

1. Place the ballhead (109) in ballhead tool 8995-061 to facilitate assembly. Install pilot valve plunger (112), compensation bushing (113), and retaining ring (114).
2. Install ballarms (110) with pins (106). Pins should fit snug as they are inserted in the ballhead. Peen pin slots if necessary.
3. Use both parts of 8995-061 to press new ball-head cover (120) on the ballhead.
4. Install pilot valve loading spring (115), lower bearing race (116), needle thrust bearing (117), upper bearing race (118), and pilot valve nut (119) on the pilot valve plunger.

5. Be sure the thrust bearing and lower bearing race are over the top land of the pilot valve before the nut is tightened. The upper bearing race will seat on the top land. Torque nut (119) to 35–40 lb-in (4.0–4.5 N·m).

IMPORTANT

To hold the pilot valve plunger while nut (119) is torqued to 35–40 lb-in (4.0–4.5 N·m), place a 1/8 inch Allen wrench in the bottom of the pvp.

6. Attach spring seat (121) to speeder spring (122). Be sure the spring is fully seated.
7. Use press fixture 8995-065 to assemble speeder plug (123), spring (124), floating lever (125), and pin (126). Use .005 shim stock to check clearance between pin head (126) and floating lever (125) while pressing pin into the speeder plug. Be sure spring (124) is in the correct position before the pin is pressed in.
8. Attach speeder spring (122) to speeder plug (123). Be sure the spring is completely seated on the plug.

Linkage and Cover Assembly

1. Install return spring (19) and loading piston seat (180).
2. Install output shaft load link(17) on terminal lever (15) with headed pin (16) and cotter pin (14).
3. Press pin (20) into droop slider (21). Attach droop slider (21) to terminal lever (15) with washer (13) and nut (12). Do not tighten nut (12) as droop adjustment will be made during governor calibration.

IMPORTANT

If zero droop tool is available, insert droop tool in place of right output shaft and center tool over pin head in droop slider. Tighten nut (12).

4. Attach terminal lever (15) to servo link (102) with headed pin (22) and cotter pin (14) (Figure 5-4).
5. Place the speeder spring and plug assembly over the pilot valve plunger adjusting nut in the ballhead.
6. Install drive coupling (108) and the ballhead assembly in the governor.
7. Use oil seal tool 8g95-060 to install oil seals (24) in case (26).
8. Place terminal lever in case and install output shafts (25) in terminal lever (15). Secure output shafts with two screws (1).
9. Press down on speeder spring plug (123) and position floating lever (125) under droop slider
10. Refer to Figure 5-14 and assemble speeder plug bracket (37). Place limit linkage rod (42) and limit/shutdown rod (40) in bracket (37). Install limit floating lever (41) as shown. Install the bracket assembly in the case and secure it with three screws (1). Be sure the fork of floating lever (41) is engaged on the headed pin in terminal lever (15).

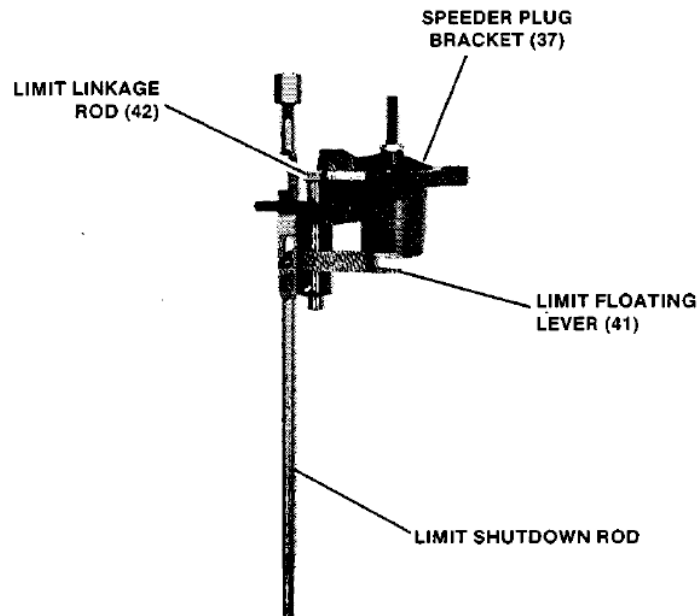

Figure 5-14. Speeder Plug Bracket Assembly

11. Install speed setting lever (36), speed setting shaft (28) and clamp screw (1). Use insert tool 8995-067 to install new speed setting shaft bearing. Shaft (28) must rotate freely.
12. Place speed setting lever stop (29) on speed setting shaft (28) but do not tighten clamp screw (32).
13. Place cover to case gasket (11) on the case. Install cover (10) and eight cover screws (1). Leave screws loose.
14. Place gasket (3) on cover and install cover cover (2) with seven screws (1).
15. Install breather cap (4) on cover (10).
16. Install fitting (9) in case (26), and fitting (7) in cover (10). Install oil gauge (8) in fitting (9) and connector (5) in top of the oil gauge. Install tube (6) in fittings (5 and 7).
17. Attach governor nameplate (30) to front of governor with four screws (1). Leave screws loose as they will be tightened after governor calibration.

Chapter 6.

Governor Calibration

Introduction

The 3161 governor must be calibrated to engine specifications. When requesting the correct specifications for your governor, contact Woodward (information on www.woodward.com). When requesting information for your governor, include the following information:

- Governor part number
- Governor serial number

General

1. Before placing the governor on the test stand, be sure the governor pump is assembled for the correct direction of rotation.
2. Install governor on the test stand.
3. Remove governor cover.
4. Set governor droop at zero.
 - (a) Place dial indicator on the speeder plug.
 - (b) If the hand on the dial indicator shows movement when moving the servo from mm. to max. position, readjust the droop slider and position the servo again. Moving the slider towards the speeder plug decreases droop, and moving it away increases droop. When zero droop has been set, tighten nut (12) on the droop slider.
5. Place test cover 8995-072 and terminal lever positioning tool 8995-073 on the governor.
6. Adjust the output shaft protractor 8995-070 to read zero degrees when the output shaft is at minimum travel.
7. Fill the governor with 2.2 liters of clean oil with a viscosity of 100–300 SUS at operating temperature (typically 150–180 °F/66–82 °C).

Calibration

1. With the governor installed on the test stand, rotate the test stand drive (100 to 400 rpm) until the governor output shaft moves to full fuel (40 degrees minimum).
2. Increase test stand speed and adjust governor speed setting so the governor controls at 20 degrees output shaft position at 900 rpm.
3. Open the governor needle valve and allow the governor to hunt for a minimum of 30 seconds. Close the needle valve until the governor is stable. Record controlling rpm. Turn the valve clockwise until the valve is completely closed. The controlling rpm should change less than 10 rpm in a 30 second time period.

4. Rapidly change the position of the output shaft 5 to 15 degrees. The controlling rpm should change several rpm, then return slowly towards the original controlling rpm at 20 degrees output shaft position.
5. Turn the needle valve counter-clockwise one turn. The speed should return to the original controlling rpm ± 3 within 10 seconds.
6. Adjust the governor to control at 400 rpm, 20 degrees output shaft position.
 - (a) The minimum torque required to force the governor output shaft to minimum fuel is 11 lb-ft or 132 lb-in (14.9 N·m).
 - (b) The minimum torque required to force the governor output shaft to maximum fuel is 10 lb-ft or 120 lb-in (13.6 N·m).
7. For an output shaft rotation from 2 degrees to 38 degrees, the change in rpm must not exceed 3 rpm. Reset the droop slider if a larger speed change occurs.
8. Remove nameplate. Set the high speed stop to the specifications for your governor. Place stop lever on serration that allows equal length of stop screws. Lock lever in place.
9. Set the low speed stop to the specifications for your governor. Adjust the speed setting indicator (if so equipped) to read "zero" and lock it in place. Set the servo stop at 40 degrees and tighten the jam nut. Install nameplate.
10. Stop governor drive shaft rotation. Depress the shutdown strap several times to bleed all governor pressure. Replace test cover with governor cover.
11. Remove the shutdown cover. Adjust the nut on the shutdown strap so the governor just begins to shutdown when top of the nut is even with the top surface of the cover, then turn the nut one turn clockwise. Replace the shutdown cover.
12. Turn the compensating needle valve clockwise to stop, and then counterclockwise 1/2 turn.
13. The governor must not have any external leaks.

Chapter 7.

Auxiliary Devices

Introduction

This chapter describes Auxiliary Devices that are available for the 3161 governor. These devices are installed and calibrated at the factory before shipment to the user. The shutdown devices may be added to a governor already in service without any further modification to the governor.

Manual	Title
03103	Manual Shutdown for the 3161 Governor
03104	Pressure Shutdown for the 3161 Governor
03105	Electric Shutdown for the 3161 Governor
03106	Pneumatic Speed Setting for the 3161 Governor (factory installed only)
03107	Speed Adjusting Motor with Manual Speed Adjustment (factory installed only)
03109	Load Limit Assembly (factory installed only)
03110	Air Pressure Fuel Limiter (factory installed only)

To obtain additional Sales or Service information for these auxiliary devices, contact Woodward or your authorized dealer or distributor.

Manual Shutdown

Figure 7-1

The manual shutdown assembly is installed on top of the right front corner of the cover. To initiate a shutdown, the threaded shutdown handle can be pushed down, or tilted in any one of 360 degrees to make contact with the shutdown rod.

The manual shutdown can also be used in conjunction with the electric or pressure shutdown devices.

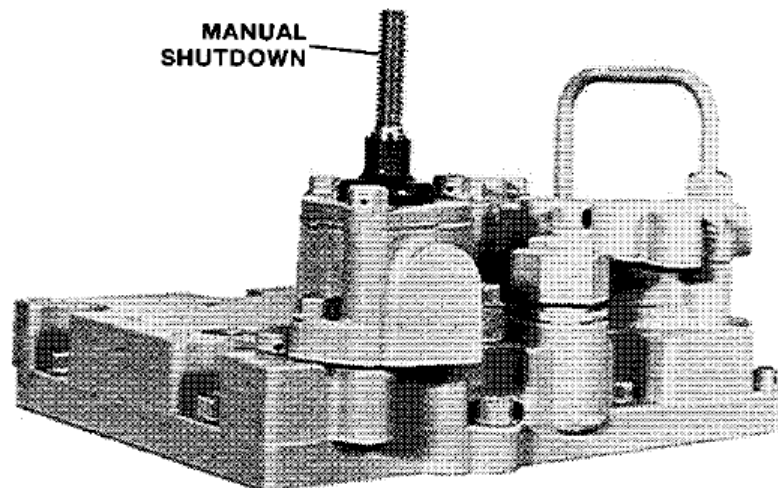

Figure 7-1. Manual Shutdown

Pressure Shutdown

Figure 7-2

The pressure shutdown assembly is installed on top of the right front corner of the cover. Forty psi pressure (either air or hydraulic) is applied to the device to cause governor shutdown. The device will reset when the pressure drops below 20 psi (138 kPa).

The pressure shutdown can be used in conjunction with the electric and/or manual shutdown devices.

WARNING

Any failure that would cause the governor to be inoperative will also cause the pressure shutdown to be inoperative.

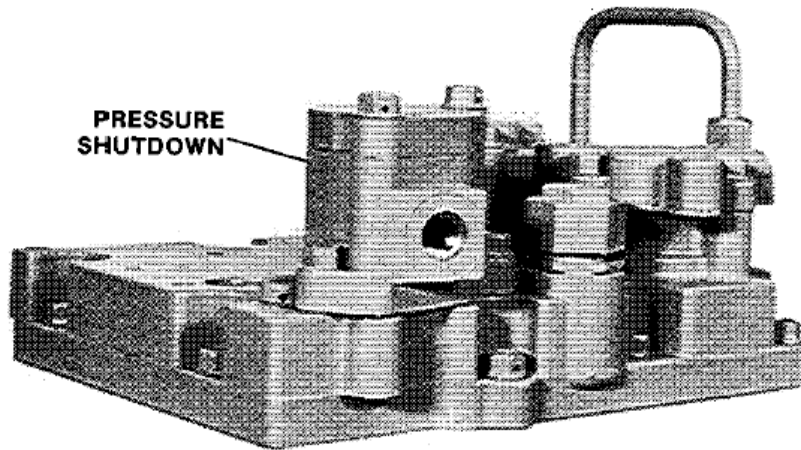

Figure 7-2. Pressure Shutdown

Electric Shutdown

Figure 7-3

The electric shutdown assembly is installed on top of the right front corner of the governor cover. The device is a 24 Vdc (energize to shutdown) solenoid that positions a shutdown lever and shutdown/limit pilot valve. The electric shutdown can be used by itself, or in conjunction with pressure and/or manual shutdowns.

WARNING

The electric shutdown must be used only as a normal shutdown device. A separate overspeed trip shutdown device must be added to provide overspeed protection.

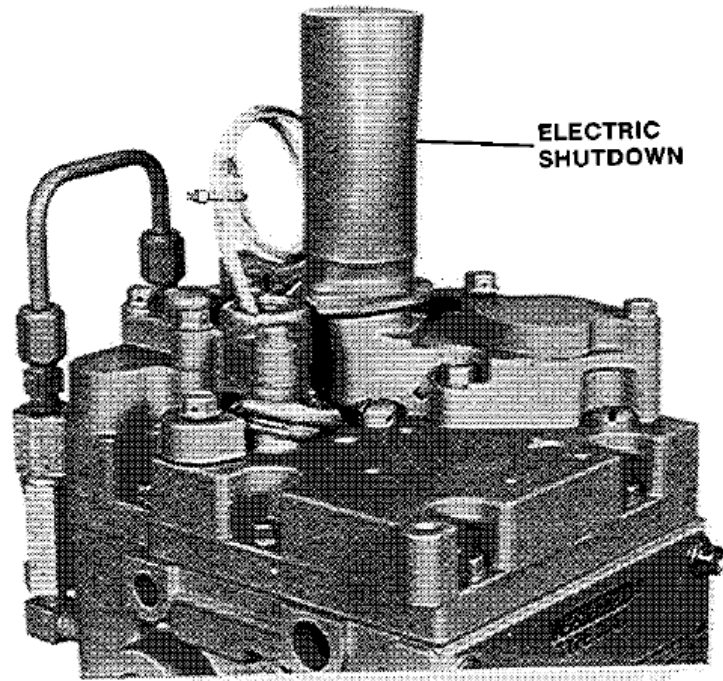

Figure 7-3. Electric Shutdown

Pneumatic Speed Setting

Figure 7-4

The pneumatic speed setting device uses an external control pressure for setting governor speed. Control pressure is supplied to a speed setting bellows. High pressure oil is supplied to the speed setting device to position the speed setting piston and rod to set governor speed.

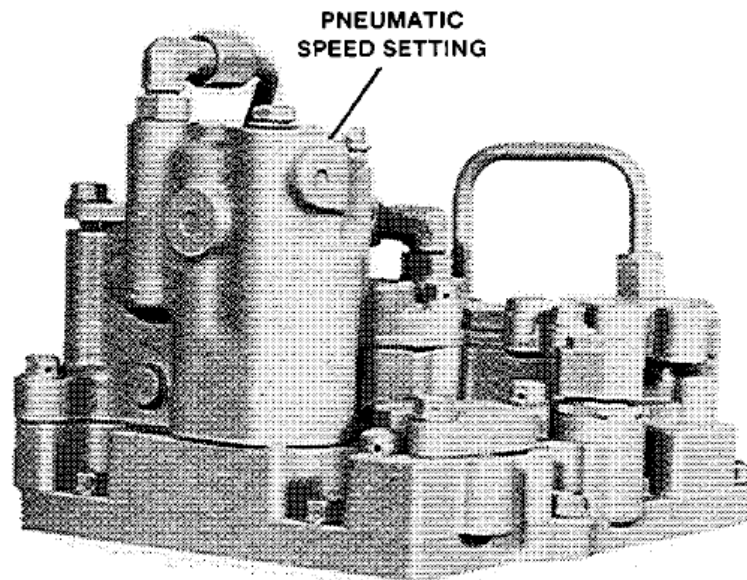

Figure 7-4. Pneumatic Speed Setting

Speed Adjusting Motor and Manual Speed Adjustment

Figure 7-5

The 24 Vdc speed adjusting motor is installed on the governor cover, and rotates a speed adjusting screw to adjust the position of the governor speed adjusting lever.

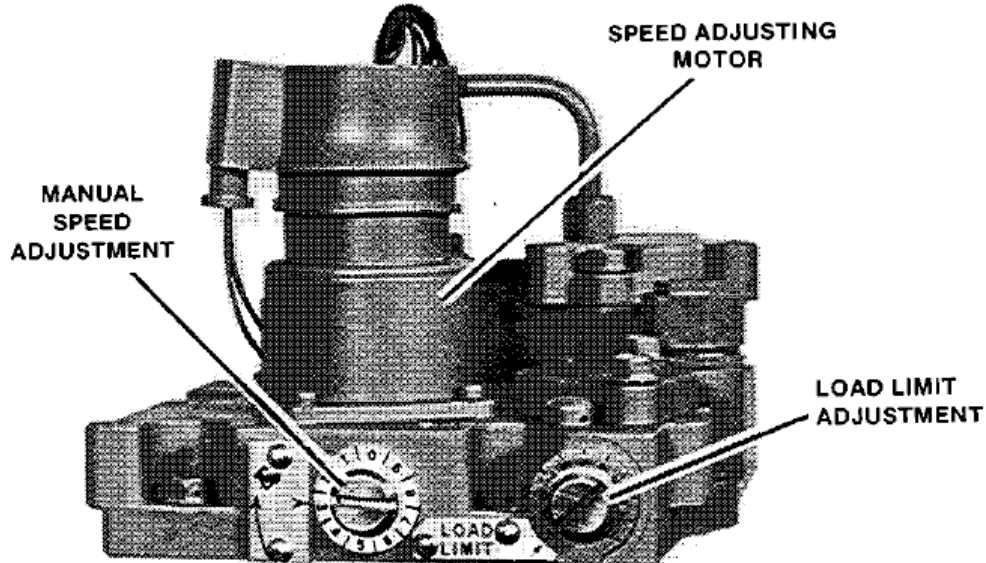

Figure 7-5. Speed Adjusting Motor and Manual Speed Adjustment

IMPORTANT

If the speed adjusting motor has been allowed to run after low speed setting has been reached, it may take a period of time for the speed adjusting screw to turn in and make contact with the speed adjusting lever when an increase in speed setting is required.

Speed can also be increased or decreased by the slotted speed setting adjustment located on the front of the governor. Turn the speed setting adjustment clockwise to increase speed setting, and counterclockwise to decrease speed setting. The high and low speed stops will limit speed adjustments.

Load Limit Assembly

The slotted load limit adjustment is located on front of the governor cover, and is set manually to a position of 0 to 10 on the load limit dial. Turning the load limit adjustment clockwise rotates an eccentric cam, limiting fuel at a higher level. Turning the adjustment counter-clockwise limits fuel at a lower level.

Air Pressure Fuel Limiter

Figure 7-6

The Air Pressure Fuel Limiter limits fuel in proportion to air pressure from the air manifold or air box, and is used to protect the turbocharger and limit smoke during acceleration.

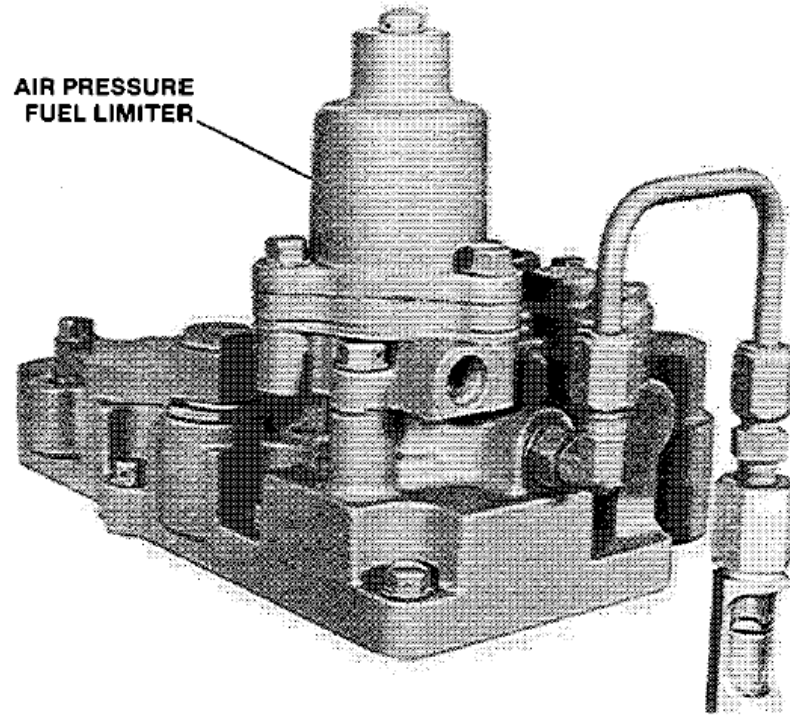

Figure 7-6. Air Pressure Fuel Limiter

Chapter 8. Replacement Parts

Parts Information

When ordering replacement parts, include the following information:

- Governor serial number and part number shown on the nameplate
- Manual number (this is manual 03101)
- Part reference number and part name from parts list

Parts List for Figure 8-1

CAUTION

Injury may result if compressed springs (77,97,19) are released suddenly. Use the proper equipment to remove springs and spring covers.

Ref. No.	Part Name.....Quantity	Ref. No.	Part Name Quantity
03101-1	Screw 0.250-20 x 1.0..... 27	03101-24	Oil seal3
03101-2	Plain cover cover 1	03101-25	Serrated terminal shaft.....2
03101-3	Cover gasket 1	03101-26	Case (includes bearings 23 and 27)....1
03101-4	Breather filter cap 1	03101-27	Bearing 0.627 x 0.3121
03101-5	Connector 0.250 x 0.125 1	03101-28	Speed setting shaft1
03101-6	Oil gauge tube 1	03101-29	Stop lever1
03101-7	Elbow..... 1	03101-30	Nameplate.....1
03101-8	Oil gauge 1	03101-31	Lockwasher 0.2501
03101-9	Fitting..... 1	03101-32	Screw 0.250-20x 1.01
03101-10	3161 cover..... 1	03101-33	Clinch nut 0.250 – 282
03101-11	Cover gasket 1	03101-34	Set screw 0.250 -28 x 1.0.....2
03101-12	Elastic nut 0.250 x 28 1	03101-35	Stop screw cover.....1
03101-13	Washer 0.265 x 0.500..... 1	03101-36	Speed setting lever1
03101-14	Cotter pin 0.062 x 0.500 1	03101-37	Speeder plug bracket.....1
03101-15	Terminal lever 1	03101-38	Set screw 0.250 -28 x 1.750.....1
03101-16	Headed pin 0.248 x 0.531..... 1	03101-39	Nut 0.250-281
03101-17	Load link 1	03101-40	Limit/shutdown rod1
03101-18	Spring seat 1	03101-41	Limit floating lever1
03101-19	Return spring 1	03101-42	Limit linkage rod1
03101-20	Droop pin 1	03101-43	Shutdown nut1
03101-21	Droop slider (includes pin 20) 1	03101-44	Shutdown cover gasket.....1
03101-22	Headed pin 0.248 x 0.719..... 1	03101-45	Shutdown cover1
03101-23	Bearing 0.627 x 0.625 2		

REFERENCE NUMBERS 1 THROUGH 45
USED ON THIS PAGE

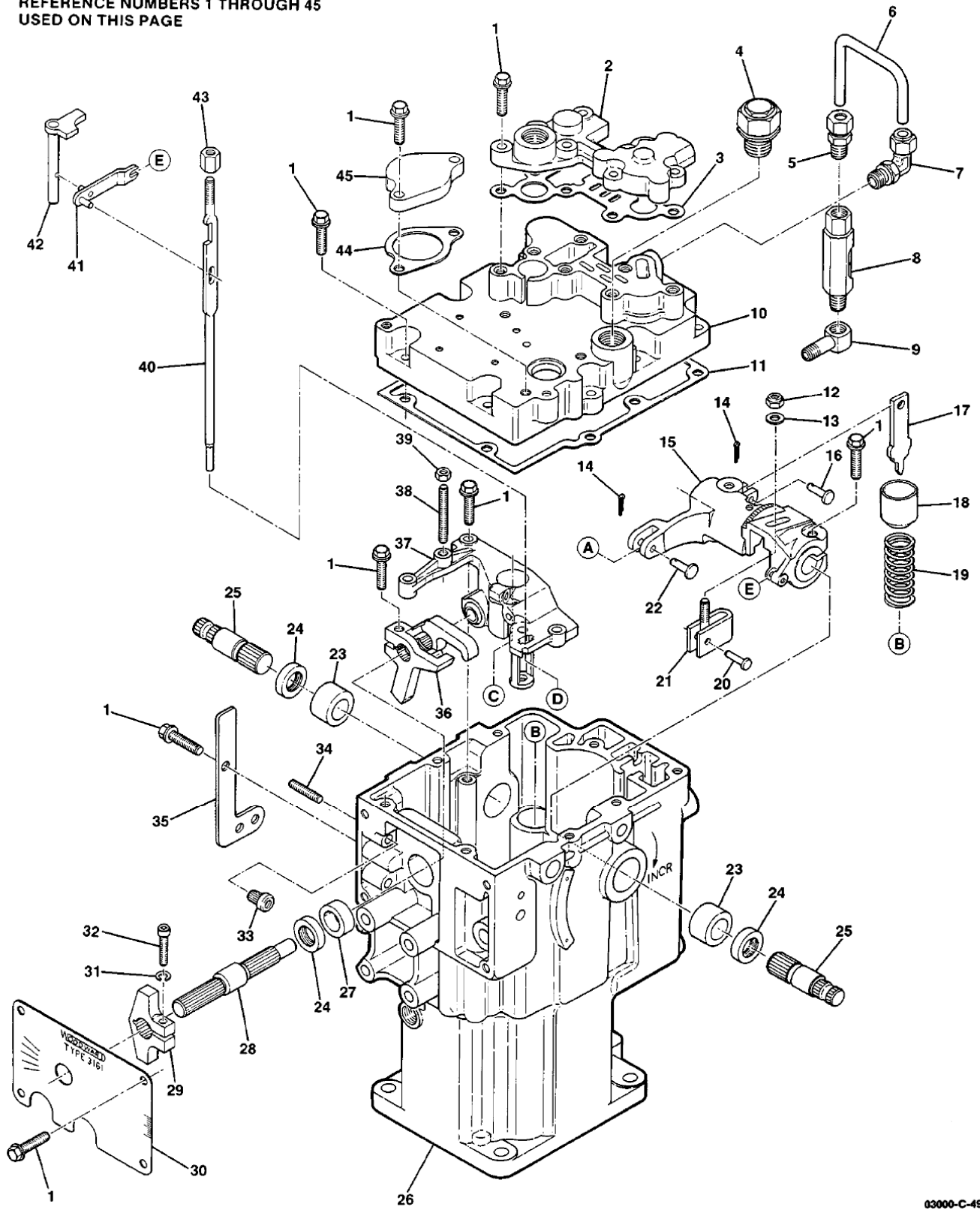

03000-C-49-1

Figure 8-1. Parts for 3161 Governor

Parts list for Figure 8-2

Ref. No.	Part Name	Quantity
03101-75	Screw	15
03101-76	Spring seat	1
03101-77	Accumulator spring	1
03101-78	Accumulator piston	1
03101-79	Gerotor pump	1
03101-80	O-ring 1.989 x 0.070	1
03101-81	Roll pin 0.125 x 0.438	1
03101-82	Pump housing	1
03101-83	O-ring 2.989 x 0.070	1
03101-84	Oil seal	1
03101-85	Not Used	
03101-86	Drive shaft	1
03101-87	Retaining ring 0.579	1
03101-88	Ball bearing	1
03101-89	Bowed retaining ring 0.579	1
03101-90	Bowed retaining ring	1
03101-91	Not Used	
03101-92	Not Used	
03101-93	Plug 0.750-16	1
03101-94	O-ring 0.644 x 0.087	1
03101-95	3161 base	1
03101-96	Gasket	1
03101-97	Buffer spring	2
03101-98	Compensating spring	1
03101-99	Retaining ring 0.338	1
03101-100	Pilot valve plunger (limit shutdown)	1
03101-101	Buffer piston	1
03101-102	Connecting link	1
03101-103	Servo piston	1
03101-104	Link pin	1
03101-105	Expansion plug	1
03101-106	Pin	2
03101-107	Roll pin 0.250 x 0.750	1
03101-108	Drive coupling (includes roll pin 107) ..	1
03101-109	Ballhead	1
03101-110	Ballarm (includes bearings 111)	2
03101-111	Needle bearing	4
03101-112	Pilot valve plunger	1
03101-113	Compensating bushing	1
03101-114	Retaining ring	1
03101-115	Loading spring	1
03101-116	Lower bearing race	1
03101-117	Thrust bearing	1
03101-118	Upper bearing race	1
03101-119	Pilot valve nut	1
03101-120	Ballhead cover	1
03101-121	Speeder spring seat	1
03101-122	Speeder spring	1
03101-123	Speeder spring plug	1
03101-124	Floating lever spring	1
03101-125	Floating lever	1
03101-126	Speeder plug pin	1
03101-127	Needle valve	1
03101-128	O-ring 0.239 x 0.070	1
03101-129	Air bleed plug	1
03101-130	O-ring 0.239 x 0.064	1

Chapter 9.

Service Options

Product Service Options

If you are experiencing problems with the installation, or unsatisfactory performance of a Woodward product, the following options are available:

- Consult the troubleshooting guide in the manual.
- Contact the manufacturer or packager of your system.
- Contact the Woodward Full Service Distributor serving your area.
- Contact Woodward technical assistance (see “How to Contact Woodward” later in this chapter) and discuss your problem. In many cases, your problem can be resolved over the phone. If not, you can select which course of action to pursue based on the available services listed in this chapter.

OEM and Packager Support: Many Woodward controls and control devices are installed into the equipment system and programmed by an Original Equipment Manufacturer (OEM) or Equipment Packager at their factory. In some cases, the programming is password-protected by the OEM or packager, and they are the best source for product service and support. Warranty service for Woodward products shipped with an equipment system should also be handled through the OEM or Packager. Please review your equipment system documentation for details.

Woodward Business Partner Support: Woodward works with and supports a global network of independent business partners whose mission is to serve the users of Woodward controls, as described here:

- A **Full Service Distributor** has the primary responsibility for sales, service, system integration solutions, technical desk support, and aftermarket marketing of standard Woodward products within a specific geographic area and market segment.
- An **Authorized Independent Service Facility (AISF)** provides authorized service that includes repairs, repair parts, and warranty service on Woodward's behalf. Service (not new unit sales) is an AISF's primary mission.
- A **Recognized Engine Retrofitter (RER)** is an independent company that does retrofits and upgrades on reciprocating gas engines and dual-fuel conversions, and can provide the full line of Woodward systems and components for the retrofits and overhauls, emission compliance upgrades, long term service contracts, emergency repairs, etc.
- A **Recognized Turbine Retrofitter (RTR)** is an independent company that does both steam and gas turbine control retrofits and upgrades globally, and can provide the full line of Woodward systems and components for the retrofits and overhauls, long term service contracts, emergency repairs, etc.

A current list of Woodward Business Partners is available at www.woodward.com/support.

Woodward Factory Servicing Options

The following factory options for servicing Woodward products are available through your local Full-Service Distributor or the OEM or Packager of the equipment system, based on the standard Woodward Product and Service Warranty (5-01-1205) that is in effect at the time the product is originally shipped from Woodward or a service is performed:

- Replacement/Exchange (24-hour service)
- Flat Rate Repair
- Flat Rate Remanufacture

Replacement/Exchange: Replacement/Exchange is a premium program designed for the user who is in need of immediate service. It allows you to request and receive a like-new replacement unit in minimum time (usually within 24 hours of the request), providing a suitable unit is available at the time of the request, thereby minimizing costly downtime. This is a flat-rate program and includes the full standard Woodward product warranty (Woodward Product and Service Warranty 5-01-1205).

This option allows you to call your Full-Service Distributor in the event of an unexpected outage, or in advance of a scheduled outage, to request a replacement control unit. If the unit is available at the time of the call, it can usually be shipped out within 24 hours. You replace your field control unit with the like-new replacement and return the field unit to the Full-Service Distributor.

Charges for the Replacement/Exchange service are based on a flat rate plus shipping expenses. You are invoiced the flat rate replacement/exchange charge plus a core charge at the time the replacement unit is shipped. If the core (field unit) is returned within 60 days, a credit for the core charge will be issued.

Flat Rate Repair: Flat Rate Repair is available for the majority of standard products in the field. This program offers you repair service for your products with the advantage of knowing in advance what the cost will be. All repair work carries the standard Woodward service warranty (Woodward Product and Service Warranty 5-01-1205) on replaced parts and labor.

Flat Rate Remanufacture: Flat Rate Remanufacture is very similar to the Flat Rate Repair option with the exception that the unit will be returned to you in “like-new” condition and carry with it the full standard Woodward product warranty (Woodward Product and Service Warranty 5-01-1205). This option is applicable to mechanical products only.

Returning Equipment for Repair

If a control (or any part of an electronic control) is to be returned for repair, please contact your Full-Service Distributor in advance to obtain Return Authorization and shipping instructions.

When shipping the item(s), attach a tag with the following information:

- return number;
- name and location where the control is installed;
- name and phone number of contact person;
- complete Woodward part number(s) and serial number(s);
- description of the problem;
- instructions describing the desired type of repair.

Packing a Control

Use the following materials when returning a complete control:

- protective caps on any connectors;
- antistatic protective bags on all electronic modules;
- packing materials that will not damage the surface of the unit;
- at least 100 mm (4 inches) of tightly packed, industry-approved packing material;
- a packing carton with double walls;
- a strong tape around the outside of the carton for increased strength.

NOTICE

To prevent damage to electronic components caused by improper handling, read and observe the precautions in Woodward manual 82715, *Guide for Handling and Protection of Electronic Controls, Printed Circuit Boards, and Modules*.

Replacement Parts

When ordering replacement parts for controls, include the following information:

- the part number(s) (XXXX-XXXX) that is on the enclosure nameplate;
- the unit serial number, which is also on the nameplate.

Engineering Services

Woodward offers various Engineering Services for our products. For these services, you can contact us by telephone, by email, or through the Woodward website.

- Technical Support
- Product Training
- Field Service

Technical Support is available from your equipment system supplier, your local Full-Service Distributor, or from many of Woodward's worldwide locations, depending upon the product and application. This service can assist you with technical questions or problem solving during the normal business hours of the Woodward location you contact. Emergency assistance is also available during non-business hours by phoning Woodward and stating the urgency of your problem.

Product Training is available as standard classes at many of our worldwide locations. We also offer customized classes, which can be tailored to your needs and can be held at one of our locations or at your site. This training, conducted by experienced personnel, will assure that you will be able to maintain system reliability and availability.

Field Service engineering on-site support is available, depending on the product and location, from many of our worldwide locations or from one of our Full-Service Distributors. The field engineers are experienced both on Woodward products as well as on much of the non-Woodward equipment with which our products interface.

For information on these services, please contact us via telephone, email us, or use our website and reference www.woodward.com/support, and then **Customer Support**.

How to Contact Woodward

For assistance, call one of the following Woodward facilities to obtain the address and phone number of the facility nearest your location where you will be able to get information and service.

Electrical Power Systems		Engine Systems		Turbine Systems	
Facility	Phone Number	Facility	Phone Number	Facility	Phone Number
Australia	+61 (2) 9758 2322	Australia	+61 (2) 9758 2322	Australia	+61 (2) 9758 2322
Brazil	+55 (19) 3708 4800	Brazil	+55 (19) 3708 4800	Brazil	+55 (19) 3708 4800
China	+86 (512) 6762 6727	China	+86 (512) 6762 6727	China	+86 (512) 6762 6727
Germany:		Germany:			
Kempen	+49 (0) 21 52 14 51	Stuttgart	+49 (711) 78954-0		
Stuttgart	+49 (711) 78954-0	India	+91 (129) 4097100	India	+91 (129) 4097100
India	+91 (129) 4097100	Japan	+81 (43) 213-2191	Japan	+81 (43) 213-2191
Japan	+81 (43) 213-2191	Korea	+82 (51) 636-7080	Korea	+82 (51) 636-7080
Korea	+82 (51) 636-7080	The Netherlands	+31 (23) 5661111	The Netherlands	+31 (23) 5661111
Poland	+48 12 618 92 00	United States	+1 (970) 482-5811	United States	+1 (970) 482-5811
United States	+1 (970) 482-5811				

You can also contact the Woodward Customer Service Department or consult our worldwide directory on Woodward's website (www.woodward.com/support) for the name of your nearest Woodward distributor or service facility.

For the most current product support and contact information, please refer to the latest version of publication **51337** at www.woodward.com/publications.

Technical Assistance

If you need to telephone for technical assistance, you will need to provide the following information. Please write it down here before phoning:

General

Your Name _____

Site Location _____

Phone Number _____

Fax Number _____

Prime Mover Information

Engine/Turbine Model Number _____

Manufacturer _____

Number of Cylinders (if applicable) _____

Type of Fuel (gas, gaseous, steam, etc) _____

Rating _____

Application _____

Control/Governor Information

Please list all Woodward governors, actuators, and electronic controls in your system:

Woodward Part Number and Revision Letter _____

Control Description or Governor Type _____

Serial Number _____

Woodward Part Number and Revision Letter _____

Control Description or Governor Type _____

Serial Number _____

Woodward Part Number and Revision Letter _____

Control Description or Governor Type _____

Serial Number _____

If you have an electronic or programmable control, please have the adjustment setting positions or the menu settings written down and with you at the time of the call.

We appreciate your comments about the content of our publications.

Send comments to: icinfo@woodward.com

Please reference publication **03101C**.



B03101:C



PO Box 1519, Fort Collins CO 80522-1519, USA
1000 East Drake Road, Fort Collins CO 80525, USA
Phone +1 (970) 482-5811 • Fax +1 (970) 498-3058

Email and Website—www.woodward.com

Woodward has company-owned plants, subsidiaries, and branches,
as well as authorized distributors and other authorized service and sales facilities throughout the world.

Complete address / phone / fax / email information for all locations is available on our website.